



LASER CATALOG

A PROGRESSIVE COMPANY FOR AN EVOLVING MARKET



Over a period of 28 years, the THERMACUT Group has undergone a multitude of changes. THERMACUT (originally Tatra Imports Inc.) was incorporated in Claremont, New Hampshire in 1990 and sold products under the brand ZAP Plasmatherm, a reseller of plasma consumables from local vendors directly to end-users. The company began operating with three employees, conducting business through telephone sales. In 1992, the company opened a small manufacturing facility in the Czech Republic, followed by a sales office there in 1996. The Czech facility was created to produce and sell plasma consumables and torches directly into the Eastern European market and through distributors in Western Europe under the brand name THERMACUT, utilizing both inside and outside sales representatives. And in 1993 the THERMACUT brand was introduced into North America and sold through distributors.

In January of 1999, STK Gesellschaft für Schweißtechnik GmbH (a holding company 100% owned by the IBG Group of Cologne, Germany) purchased 80% of the shares of THERMACUT and in 2002 completed the acquisition to become the 100% shareholder of the THERMACUT Group.

Since those early and humble beginnings, THERMACUT has evolved into a major force in providing plasma torches and consumables through multiple sales channels supported by ten sales subsidiaries. THERMACUT also has a close partnership with Abicor-Binzel (an IBG owned company) with locations in India, the Middle East, Turkey, Belarus, Kazakhstan, Denmark, Norway, Sweden, Finland, United Kingdom, South Korea, Australia, Mexico, and Brazil. Based on customer demand, THERMACUT has also introduced TIG/WIG, MIG/MAG and Oxy-fuel products and produces those products at its modern ISO 9001 production facility located in Uherske Hradiste in the Czech Republic.

The THERMACUT Group has focused its efforts on providing high quality, direct replacement consumable and torch product lines that will meet or exceed the expectations of our valued customers who are cutting and welding metals thermally throughout the world. As our customer base grew, their expectations and demands also increased. In 2005, THERMACUT expanded its product portfolio with the addition of advanced consumables, which have included products such as the Silver Plus™, Silver Pro™ and Silver-EX® electrodes, plus the patented Tungsten-EX™ nozzles.

By 2013, the THERMACUT Group continued to expand and evolve in the thermal cutting and welding marketplace. In December of 2012, the THERMACUT Group concluded the purchase of the HOLMA® AG, a producer of premium quality laser consumables, which satisfies ongoing requests from customers for a high quality laser consumable brand and a further expansion of THERMACUT's plasma cutting and oxy-fuel consumable product portfolio.

In September 2013 at the SCHWEISSEN & SCHNEIDEN Exposition, the THERMACUT Group evolved once again with the introduction of a line of plasma cutting systems for both manual and mechanized plasma processes up to 65 mm thickness. The initial introduction featured a 105 amp system. THERMACUT also had 65 and 85 amp systems on display. With this change, THERMACUT has made clear to its customers around the world its intention to move into the position of a producer of a full range of original plasma products.

From 2016 to 2018, plasma power sources from 30 A to 125 A were gradually introduced. The HD series, along with its original torches and the patented Torch Connection System (TCS) connector, was launched in 2017 at SCHWEISSEN & SCHNEIDEN in Dusseldorf.

As with plasma cutting, THERMACUT is the leader in the field of laser cutting technology. In 2017 at SCHWEISSEN & SCHNEIDEN, we presented the original EX-TRABEAM® laser head, which was launched in the second half of 2018.

Throughout the life of the THERMACUT Group, we have believed that "The customer is always right." This is what motivates us to improve in all areas, starting with the development of all products and ending their sales.

"THE CUTTING COMPANY" is not just a slogan for us. It is an established practice. Join THERMACUT in the world of cutting to discover new and alternative applications, and take full advantage of new possibilities offered by the digital cutting world.



ADDRESSES AND CONTACTS

CZECH REPUBLIC

THERMACUT, k.s.
Headquarters and Production
Sokolovská 574, Mařatice
686 01 Uherské Hradiště
Tel.: +420 572 420 411
Fax: +420 572 420 420
E-mail: info@thermacut.cz
reditelstvi@thermacut.cz
www.thermacut.cz

CZECH REPUBLIC

THERMACUT, k.s.
Central Sales Department
Dukelská 76A
742 42 Šenov u Nového Jičína
Tel.: +420 556 423 418, 440
E-mail: sales@thermacut.cz
obchod@thermacut.cz
www.thermacut.cz

GERMANY

THERMACUT GmbH
Essener Str. 1
D-57234
Wilnsdorf
Tel.: +49 2739-4033-0
Fax: +49 2739 4033 77
E-mail: info@thermacut.de
www.thermacut.de

USA

THERMACUT, Inc
153 Charlestown Road
Claremont, NH 03743
Tel.: +1 (800) 932-8312
+1 (603) 543-0585
Fax: +1 (800) 972-6255
+1 (603) 542-2867
E-mail: sales@thermacut.com
www.thermacut.com

SUBSIDIARIES

CROATIA

THERMACUT CROATIA d.o.o.
Daničićeva 12
532 70 Senj
Tel.: +385 53 882 599
Fax: +385 53 882 622
E-mail: thermacut@gs.t-com.hr

HUNGARY

THERMACUT HUNGÁRIA Kft.
Petőfi Sándor utca 37 atd.
2500 Esztergom
Tel.: +36 33 502 090,1
Fax: +36 33 400 004
E-mail: info@thermacut.hu
www.thermacut.hu

CHINA

TMT (Shanghai) Cutting and Welding
Equipment Co., Ltd.
Room 206 2/F, B Block, Eternal Asia Plaza,
No. 3333 Shenjiang Road, Shanghai
Post: 201206
Tel.: 021-50390667
Fax: 021-50390677
E-mail: thermacut@weldstone.cn

JAPAN

Thermacut Japan Ltd.
3F Shin-Osaka Hankyu Building
1-1-1, Miyahara, Yodogawa-ku, Osaka
532-0003 Japan
Mob.: +81 (0)80 4738 9752
Tel.: +81 (0)6 7662 8857
Fax: +81 (0)6 7668 8301
E-mail: s.miura@thermacut.jp

SUBSIDIARIES

POLAND

THERMACUT-POLAND Sp. z o.o.
ul. Stawowa 20
43-400 Cieszyn
Tel.: +48 33 852 39 71
Tel./Fax: +48 33 852 13 34
E-mail: thermacut@pro.onet.pl
www.thermacut.pl

ROMANIA

THERMACUT ROMANIA SRL
B-dul 1 Decembrie 1918
nr. 127A
540445 Targu Mures,
Jud. Mures
Tel.: +40 265 263 205
Fax: +40 265 250 317
E-mail: office@thermacut.ro
www.thermacut.ro

RUSSIA

ООО "ТЕРМАКАТ"
454048Г. ЧЕЛЯБИНСК
УЛ. КИРОВОГРАДСКАЯ Д.2
Тел./факс: +7 351 211 08 15

ФИЛИАЛЫ

129343 Г. МОСКВА
УЛ. УРЖУМСКАЯ Д.4
Тел.: +7 495 778 42 10

630032 Г. НОВОСИБИРСК
УЛ. СТАНЦИОННАЯ 60/1, ОФИС 116
Тел.: +7 383 375 07 90

E-mail: info@thermacut.ru
www.thermacut.ru

SLOVAKIA

THERMACUT SLOVAKIA, s.r.o.
M. R. Štefánika 14
942 01 Šurany
Mob.: +421 190 3644954
Tel.: +421 356 501516-7
Fax: +421 356 501518
E-mail: obchod@thermacut.sk
www.thermacut.sk

UKRAINE

ООО "Термакат Украина ГмбХ"
ул. Петропавловская 24
с. Петропавловская Борщаговка
Киево-Святошинский р-н 08130
Моб. тел.: +380 50 336 33 91
Тел./факс: +380 44 403 16 99
E-mail: info@thermacut.ua
www.thermacut.ua

SALES COOPERATION WITH ABICOR-BINZEL

AUSTRALIA

Binzel PTY Ltd.
42 Hinkler Road
Mordialloc
Victoria 3195
Tel.: +61 (0)3 9587 8522
Fax: +61 (0)3 9580 8796
E-mail: sales@thermacut.com.au

BELARUS

IOOO «ABICOR BINZEL Technics»
ul. Timirjazeva 97-10
BY-220020 Minsk
Tel.: +375 29 5 800 300
E-mail: info@thermacut.by

BRAZIL

BINZEL DO BRASIL INDUSTRIAL Ltda
Estrada União e Indústria, Km 15,5-Lt 17,
Pedro do Rio,
Petrópolis - Rio de Janeiro, CEP 25750-226
Tel.: +55 (24) 2222-9799
+55 (24) 2222-9789
Mob.: +(24) 98134-2676
Fax: +55 (24) 2222-9789
E-mail: thermacut@thermacut.com.br
www.thermacut.com.br

DENMARK

Abicor Binzel A/S Denmark
Ringugngsgatan 4
SE-216 16 Limhamn
Tel.: 0045-43621633
Fax: 0045-43622324
E-mail: ac@binzel.se, ket@binzel.se
www.binzel-abicor.com

FINLAND

ABICOR BINZEL Finland Oy
Kartanontie 53
28430 Pori
Tel.: +358 2 634 4600
Fax: +358 2 634 4650
E-mail: info@binzel.fi

FRANCE

THERMACUT FRANCE
6 Rue des Frères Lumiere
67201 Eckbolsheim
Tel.: +33 3 88 76 58 75
E-mail: thermacut@thermacut.fr
www.thermacut.fr

GREAT BRITAIN

Abicor Binzel UK Ltd
Binzel House,
Mill Lane
Winwick Quay
Warrington,
WA2 8UA, Cheshire
Tel.: +44 1925 653944
Fax: +44 1925 654861
E-mail: info@abimail.co.uk
www.binzel-abicor.co.uk

INDIA

ABICOR BINZEL TECHNOWELD PVT LTD
SNo: 297, Indo German Technology park
Urawade
Mulshi
Pune- 412 115
Phone: 020-66743914, 020-39502691
E-mail: commercial@abicor-india.com

KAZAKHSTAN

THERMACUT
Республика Казахстан.
010000, г. Астана
пр. Республики 68, БЦ «Маржан» офис 116
Моб.: +7 777 826 4242
Тел.: +7 717 262 5730
E-mail: info@thermacut.com.kz
www.thermacut.kz

SALES COOPERATION WITH ABICOR-BINZEL

MEXICO

BINZEL MEXICO S.A. de C.V.
C. Municipio de Tepezalá No. 109
de Arteaga No. 102
Valle de Ags., C.P. 20358
San Fco. de los Romo, Ags.
Tel.: +52 (449) 1581765
Fax: +52 (449) 9731388
E-mail: info@thermacut.com.mx
www.thermacut.com.mx

NORWAY

Binzel Norge AS
Industriveien 6
N-3300 Hokksund
Tel.: 0047-32 25 19 90
E-mail: post@binzel.no

SOUTH KOREA

Abicor Binzel Korea Ltd.
#A-101, 263, Gaejwa-ro
Guemjeong-gu
Busan
Tel.: 0082 (31) 732 6065 / 6066 / 6067
Fax: 0082 (31) 732 6064
E-mail: don.kim@binzel.kr

SWEDEN

Alexander Binzel AB
Ringugngsgatan 4
S-21616 Limhamn
Tel.: 0046- 40 6 991 750
Fax: 0046- 40 6 991 770
E-mail: order@binzel.se

TURKEY

ABICOR BINZEL Kaynak Teknik
Ticaret LTD. STI.
Girne Mah. Irmak Sok. Küçükyalı İş Merkezi E
Blok
No:72-6E PK:34852
Maltepe İstanbul Türkiye
Tel.: +90 (216) 367 90 00
Fax: +90 (533) 367 90 14
E-mail: info@thermacuttr.com,
info@binzel-abicor.com.tr
www.thermacut.com.tr

UNITED ARAB EMIRATES

ABICOR BINZEL MIDDLE EAST FZE
P.O Box: 86026, WFZ-04/27, RAKIA Freezone,
Jazeera al Hamra
Ras al Khaimah, United Arab Emirates
Mob.: +971 50 377 1348
Tel.: +971 (7) 2432355
Fax: +971 (7) 2432356
E-mail: info@binzel-abicor.ae

VIETNAM

MNT Industries Vietnam Co Ltd
No. 17, Street 34, Binh Tri Dong B Ward, Binh
Tan District, Hochiminh City
Tel.: 0084-903 858 001
E-mail: ezio.minh@mnt.com.vn

TABLE OF CONTENTS

LASER

| SYSTEM | PAGE |
|---|-------|
| THERMACUT® REPLACEMENT PARTS SUITABLE FOR AMADA® | 8-10 |
| BYSTRONIC® | 11-13 |
| AIR FILTERS suitable for BYSTRONIC® | 13 |
| CINCINNATI® | 14-15 |
| LVD® | 16 |
| MAZAK® | 17-21 |
| MITSUBISHI® | 22-23 |
| Precitec® | 24-29 |
| PRIMA POWER® | 30-31 |
| TRUMPF® | 32-39 |
| AIR FILTERS suitable for TRUMPF® | 40 |
| RAYTOOLS™ | 41 |
| BODOR™ | 41 |

THERMACUT® REPLACEMENT PARTS SUITABLE FOR AMADA® AMADA® LASER AHST™ 100

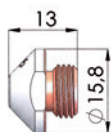

HG10.508

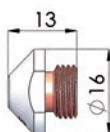

HG10.509

| Part No. | Ref. No. | Description | Std. Pkg. | Part No. | Ref. No. | Description | Std. Pkg. |
|----------|--------------|--------------------------|-----------|----------|--------------|--------------------------|-----------|
| HG10.508 | 62094006-1.3 | Nozzle 1.3mm M10 × 1 HCP | 10pcs | HG10.506 | 62094006-2.0 | Nozzle 2.0mm M10 × 1 HCP | 10pcs |
| HG10.509 | 62094006-1.5 | Nozzle 1.5mm M10 × 1 HCP | 10pcs | | | | |

SUITABLE FOR AMADA® F.O.™

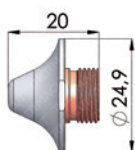

HG10.608-HG10.614

Standard/Double copper nozzles with chromium plating

| Part No. | Ref. No. | Description | Std. Pkg. | Part No. | Ref. No. | Description | Std. Pkg. |
|----------|-------------|-------------------------|-----------|----------|-------------|-------------------------|-----------|
| HG10.609 | 1572362-0.8 | Nozzle 0.8mm HCP | 10pcs | HG10.592 | 1572361-1.4 | Double Nozzle 1.4mm HCP | 10pcs |
| HG10.610 | 1572362-1.2 | Nozzle 1.2mm HCP | 10pcs | HG10.595 | 1572361-2.0 | Double Nozzle 2.0mm HCP | 10pcs |
| HG10.613 | 1572362-1.4 | Nozzle 1.4mm HCP | 10pcs | HG10.618 | 1572361-2.5 | Double Nozzle 2.5mm HCP | 10pcs |
| HG10.608 | 1572362-1.5 | Nozzle 1.5mm HCP | 10pcs | HG10.599 | 1572361-3.0 | Double Nozzle 3.0mm HCP | 10pcs |
| HG10.611 | 1572362-2.0 | Nozzle 2.0mm HCP | 10pcs | HG10.593 | 1572361-4.0 | Double Nozzle 4.0mm HCP | 10pcs |
| HG10.612 | 1572362-3.0 | Nozzle 3.0mm HCP | 10pcs | HG10.759 | 71515853 | PTFE ring | 1pc |
| HG10.614 | 1572362-4.0 | Nozzle 4.0mm HCP | 10pcs | | | | |
| HG10.594 | 1572361-1.2 | Double Nozzle 1.2mm HCP | 10pcs | | | | |

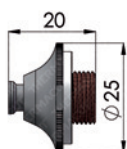

HG10.763, HG10.765, HG10.766

| Part No. | Ref. No. | Description | Std. Pkg. | Part No. | Ref. No. | Description | Std. Pkg. |
|----------|----------|--|-----------|----------|----------|--|-----------|
| HG10.763 | HG10.763 | WACS - Double Nozzle 1.7mm with holes Hard chrom (PTFE Ring included) | 1pc | HG10.766 | 71712336 | WACS - Double Nozzle 4.0mm with holes Hard chrom (PTFE Ring included) | 1pc |
| HG10.765 | 71712335 | WACS - Double Nozzle 2.5mm with holes Hard chrom (PTFE Ring included) | 1pc | HG10.773 | 71341728 | Clean Cut Double Nozzle 4.0mm HCP | 1pc |
| | | | | HG10.776 | 71341729 | Clean Cut Double Nozzle 7.0mm HCP | 1pc |

PolyTetraFluoroEthylene is a fluorocarbon-based polymer and is commonly abbreviated PTFE. The Teflon® brand of PTFE is manufactured only by DuPont® and is not sold by Thermacut. Thermacut purchases other brands of PTFE from various high quality manufacturers.

Last update of this page: 02/07/2018. See Revision history for details.

THERMACUT®
THE CUTTING COMPANY™

WWW.THERMACUT.CZ
TEL.: +420 556 423 418
SALES@THERMACUT.CZ

WWW.THERMACUT.DE
TEL.: +49 (0) 27 39 40 33 0
INFO@THERMACUT.DE

WWW.THERMACUT.COM
TEL.: 1-603-542-6715
CUSTOMERSERVICE@THERMACUT.COM

THERMACUT®, THE CUTTING COMPANY®, FHT-EX®, EX-TRAFIRE®, EX-TRACK®, EX-TRABEAM® AND EX-TRAFLEAME® ARE REGISTERED TRADEMARKS OF THERMACUT, K.S. AND MAY BE REGISTERED IN CZECH REPUBLIC AND/OR OTHER COUNTRIES. ALL OTHER TRADEMARKS ARE PROPERTIES OF THEIR RESPECTIVE OWNERS. THERMACUT IS NO WAY AFFILIATED WITH AMADA® AND E.I. DU PONT DE NEMOURS AND COMPANY. MOST THERMACUT PARTS ARE MADE FOR OR BY AN IBG COMPANY.
VALID FROM JANUARY 2021 • PREVIOUS VERSION IS NO LONGER VALID. • © COPYRIGHT 2021 BY THERMACUT® CZECH REPUBLIC. ALL RIGHTS RESERVED.

THERMACUT® REPLACEMENT PARTS SUITABLE FOR AMADA® AMADA® LC-3015 X1™

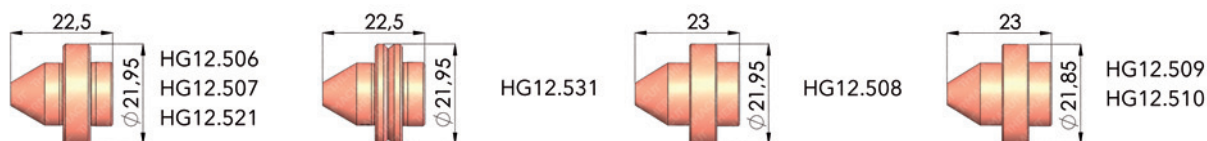

| Part No. | Ref. No. | Description | Std. Pkg. | Part No. | Ref. No. | Description | Std. Pkg. |
|----------|--------------|---------------------------|-----------|----------|--------------|---------------------------------|-----------|
| HG11.500 | HG11.500 | Nozzle 0.8mm Fe CP | 10pcs | HG12.508 | BQ943D157H02 | Nozzle 2.0mm | 10pcs |
| HG11.501 | 71570021 | Nozzle 1.0mm Fe CP | 10pcs | HG12.509 | BQ943D157H03 | Nozzle 2.5mm | 10pcs |
| HG11.502 | 71570020 | Nozzle 1.2mm Fe CP | 10pcs | HG12.510 | BQ943D157H04 | Nozzle 3.0mm | 10pcs |
| HG11.503 | HG11.503 | Nozzle 1.4mm Fe CP | 10pcs | HG12.521 | BQ943D596H01 | Nozzle 3.5mm | 10pcs |
| HG11.504 | 71570022 | Double Nozzle 2.0mm Fe CP | 10pcs | HG12.522 | HG12.522 | Nozzle 4.0mm | 10pcs |
| HG11.505 | HG11.505 | Double Nozzle 2.5mm Fe CP | 10pcs | HG12.532 | BQ933D283H01 | Nozzle 1.0mm | 10pcs |
| HG11.506 | HG11.506 | Double Nozzle 4.0mm Fe CP | 10pcs | HG12.520 | BQ943D269H01 | Nozzle 1.2mm | 10pcs |
| HG12.506 | BQ943D897H01 | Nozzle 1.0mm | 10pcs | HG12.530 | BQ933D094H01 | Nozzle Nut, Short (length 15mm) | 1pc |
| HG12.507 | BQ943D157H01 | Nozzle 1.5mm | 10pcs | HG12.501 | BQ943D156H01 | Double Nozzle Insert 8-holes | 10pcs |
| HG12.531 | HG12.531 | Nozzle 1.7mm | 10pcs | HG12.504 | BQ943D156H03 | Double Nozzle Insert 24-holes | 10pcs |

LENSES SUITABLE FOR AMADA® LC-3015 X1™



| Part No. | Ref. No. | Description | Std. Pkg. | Part No. | Ref. No. | Description | Std. Pkg. |
|------------|------------|---|-----------|-------------|-------------|--|-----------|
| HG15.029/H | HG15.029/H | 5.00" ZnSe Plano-convex lens High pressure lens (19bar), 50.8mm Effective focal length: 127.0mm Edge thickness: 7.87mm AR/AR for 10.6µm (absorption <0.20%) | 1pc | HG15.029/HU | HG15.029/HU | 5.00" ZnSe Plan.-con. - ULTRA LOW High pressure lens (19bar), 50.8mm Effective focal length: 127.0mm Edge thickness: 7.87mm AR/AR for 10.6µm (absorption <0.13%) | 1pc |
| HG15.028/H | HG15.028/H | 7.50" ZnSe Plano-convex lens High pressure lens (19bar), 50.8mm Effective focal length: 190.5mm Edge thickness: 7.87mm AR/AR for 10.6µm (absorption <0.20%) | 1pc | HG15.028/HU | HG15.028/HU | 7.50" ZnSe Plan.-con. - ULTRA LOW High pressure lens (19bar), 50.8mm Effective focal length: 190.5mm Edge thickness: 7.87mm AR/AR for 10.6µm (absorption <0.13%) | 1pc |

Last update of this page: 27/04/2020. See Revision history for details.

THERMACUT®
THE CUTTING COMPANY™

WWW.THERMACUT.CZ
TEL.: +420 556 423 418
SALES@THERMACUT.CZ

WWW.THERMACUT.DE
TEL.: +49 (0) 27 39 40 33 0
INFO@THERMACUT.DE

WWW.THERMACUT.COM
TEL.: 1-603-542-6715
CUSTOMERSERVICE@THERMACUT.COM

THERMACUT®, THE CUTTING COMPANY®, FHT-EX®, EX-TRAFIRE®, EX-TRACK®, EX-TRABEAM® AND EX-TRAFLEAME® ARE REGISTERED TRADEMARKS OF THERMACUT, K.S. AND MAY BE REGISTERED IN CZECH REPUBLIC AND/OR OTHER COUNTRIES. ALL OTHER TRADEMARKS ARE PROPERTIES OF THEIR RESPECTIVE OWNERS. THERMACUT IS NO WAY AFFILIATED WITH AMADA®. MOST THERMACUT PARTS ARE MADE FOR OR BY AN IBG COMPANY.
VALID FROM JANUARY 2021 • PREVIOUS VERSION IS NO LONGER VALID. • © COPYRIGHT 2021 BY THERMACUT® CZECH REPUBLIC. ALL RIGHTS RESERVED.

THERMACUT® REPLACEMENT PARTS SUITABLE FOR AMADA® LENSES SUITABLE FOR AMADA®



| Part No. | Ref. No. | Description | Std. Pkg. | Part No. | Ref. No. | Description | Std. Pkg. |
|------------|----------|--|-----------|-------------|----------|---|-----------|
| HG10.167/H | M78025 | 5.00" ZnSe Meniscus lens High pressure lens (29bar), 38.1mm Effective focal length: 127.0mm Edge thickness: 7.4mm AR/AR for 10.6µm (absorption <0.20%) | 1pc | HG10.167/HU | M78025UL | 5.00" ZnSe Men. lens - ULTRA LOW High pressure lens (29bar), 38.1mm Effective focal length: 127.0mm Edge thickness: 7.4mm AR/AR for 10.6µm (absorption <0.13%) | 1pc |
| HG10.168/H | M78026 | 7.50" ZnSe Meniscus lens High pressure lens (29bar), 38.1mm Effective focal length: 190.5mm Edge thickness: 7.4mm AR/AR for 10.6µm (absorption <0.20%) | 1pc | HG10.168/HU | M78026UL | 7.50" ZnSe Men. lens - ULTRA LOW High pressure lens (29bar), 38.1mm Effective focal length: 190.5mm Edge thickness: 7.4mm AR/AR for 10.6µm (absorption <0.13%) | 1pc |
| HG15.002/H | M78037 | 5.00" ZnSe Plano-convex lens High pressure lens (28bar), 50.8mm Effective focal length: 127.0mm Edge thickness: 9.7mm AR/AR for 10.6µm (absorption <0.20%) | 1pc | HG15.002/HU | M78037UL | 5.00" ZnSe Plan.-con. - ULTRA LOW High pressure lens (28bar), 50.8mm Effective focal length: 127.0mm Edge thickness: 9.7mm AR/AR for 10.6µm (absorption <0.13%) | 1pc |
| HG15.003/H | M78038 | 7.50" ZnSe Plano-convex lens High pressure lens (28bar), 50.8mm Effective focal length: 190.5mm Edge thickness: 9.7mm AR/AR for 10.6µm (absorption <0.20%) | 1pc | HG15.003/HU | M78038UL | 7.50" ZnSe Plan.-con. - ULTRA LOW High pressure lens (28bar), 50.8mm Effective focal length: 190.5mm Edge thickness: 9.7mm AR/AR for 10.6µm (absorption <0.13%) | 1pc |

PROTECTION WINDOWS SUITABLE FOR AMADA®

| Part No. | Ref. No. | Description | Std. Pkg. |
|----------|----------|--|-----------|
| HG17.521 | HG17.521 | Protection Window D33.00mm × ET = 1.50mm | 1pc |
| HG17.522 | HG17.522 | Protection Window D19.00mm × ET = 1.0mm | 1pc |

ACCESSORIES SUITABLE FOR AMADA®

| Part No. | Ref. No. | Description | Std. Pkg. |
|----------|----------|---|-----------|
| HG10.174 | HG10.174 | Polish for laser optics, 100ml | 1pc |
| HG10.173 | HG10.173 | Lens cleaning paper from TIFFEN®, sheet size 70 × 115mm | 50pcs |

Last update of this page: 02/01/2017. See Revision history for details.

THERMACUT®
THE CUTTING COMPANY™

WWW.THERMACUT.CZ
TEL.: +420 556 423 418
SALES@THERMACUT.CZ

WWW.THERMACUT.DE
TEL.: +49 (0) 27 39 40 33 0
INFO@THERMACUT.DE

WWW.THERMACUT.COM
TEL.: 1-603-542-6715
CUSTOMERSERVICE@THERMACUT.COM

THERMACUT®, THE CUTTING COMPANY®, FHT-EX®, EX-TRAFIRE®, EX-TRACK®, EX-TRABEAM® AND EX-TRAFLEAME® ARE REGISTERED TRADEMARKS OF THERMACUT, K.S. AND MAY BE REGISTERED IN CZECH REPUBLIC AND/OR OTHER COUNTRIES. ALL OTHER TRADEMARKS ARE PROPERTIES OF THEIR RESPECTIVE OWNERS. THERMACUT IS NO WAY AFFILIATED WITH AMADA® AND THE TIFFEN COMPANY. MOST THERMACUT PARTS ARE MADE FOR OR BY AN IBG COMPANY.
VALID FROM JANUARY 2021 • PREVIOUS VERSION IS NO LONGER VALID. • © COPYRIGHT 2021 BY THERMACUT® CZECH REPUBLIC. ALL RIGHTS RESERVED.

**THERMACUT® REPLACEMENT PARTS SUITABLE FOR
BYSTRONIC®
BYSTRONIC® "BY" SERIES**

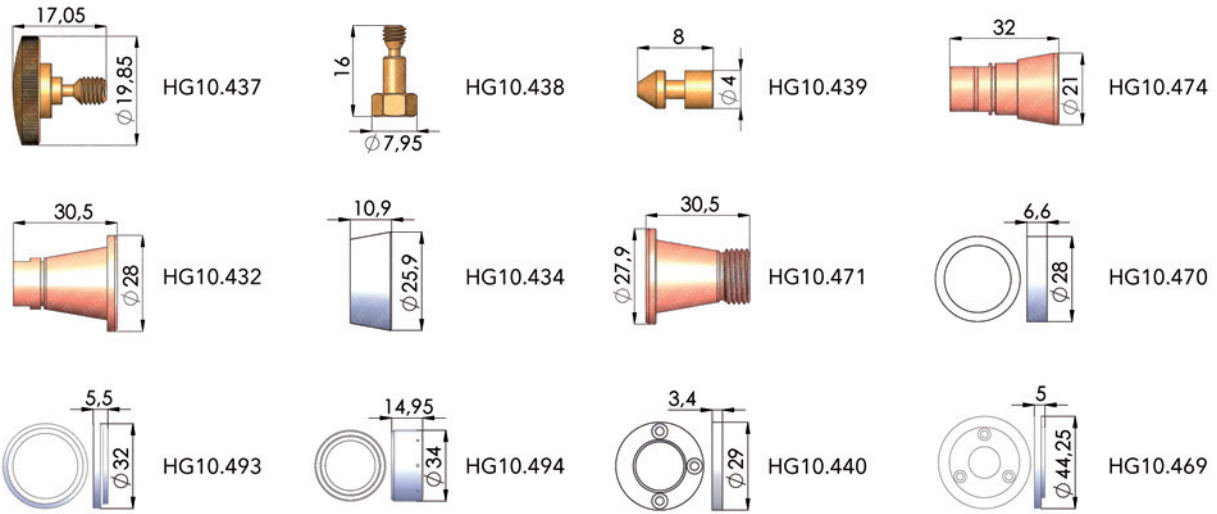

| Part No. | Ref. No. | Description | Std. Pkg. | Part No. | Ref. No. | Description | Std. Pkg. |
|----------|----------|---------------------------|-----------|----------|----------|------------------------------------|-----------|
| HG10.437 | 4-03136 | Knurled Screw | 1pc | HG10.472 | 2-08700 | Shield (copper) | 1pc |
| HG10.438 | 4-00324 | Knurled Screw | 1pc | HG10.493 | 3-13113 | Insulating Ring (small) | 1pc |
| HG10.439 | 4-03137 | Pin | 1pc | HG10.495 | 2-10837 | Nozzle Body | 1pc |
| HG10.474 | 3-02291 | Nozzle Body | 1pc | HG10.488 | 10032930 | Nozzle Body | 1pc |
| HG10.433 | 4-01642 | Insulating Ring - Ceramic | 1pc | HG10.494 | 3-13422 | Insulating Ring (large) | 1pc |
| HG10.432 | 3-05497 | Nozzle Body | 1pc | HG10.440 | 3-06035 | Insulating Disc (PTFE) | 1pc |
| HG10.434 | 4-01959 | Conical Ceramic | 1pc | HG10.469 | 3-03663 | Insulating Disc (PTFE) - old. ref. | 1pc |
| HG10.471 | 2-08701 | Nozzle Body | 1pc | HG10.496 | 10055576 | Nozzle Holder BySprint™ | 1pc |
| HG10.473 | 3-11071 | Fastener Nut | 1pc | HG10.497 | 10051133 | Nozzle Holder BySprint™ | 1pc |
| HG10.470 | 4-09010 | Ceramic | 1pc | | | | |

PARTS SUITABLE FOR BYSTRONIC® "BY" SERIES

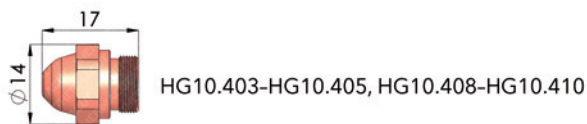

| Part No. | Ref. No. | Description | Std. Pkg. | Part No. | Ref. No. | Description | Std. Pkg. |
|----------|----------|---------------------|-----------|----------|----------|---------------------|-----------|
| HG10.403 | 3-01894 | Nozzle 1.0mm - 10 | 10pcs | HG10.411 | 3-01902 | Nozzle 1.75mm - H17 | 10pcs |
| HG10.404 | 3-01895 | Nozzle 1.25mm - 12 | 10pcs | HG10.412 | 3-01903 | Nozzle 2.0mm - H20 | 10pcs |
| HG10.405 | 3-01896 | Nozzle 1.50mm - 15 | 10pcs | HG10.413 | 3-01905 | Nozzle 1.0mm - K10 | 10pcs |
| HG10.408 | 3-01899 | Nozzle 1.00mm - H10 | 10pcs | HG10.414 | 3-01906 | Nozzle 1.25mm - K10 | 10pcs |
| HG10.409 | 3-01900 | Nozzle 1.25mm - H12 | 10pcs | HG10.415 | 3-01907 | Nozzle 1.50mm - K15 | 10pcs |
| HG10.410 | 3-01901 | Nozzle 1.50mm - H15 | 10pcs | | | | |

PolyTetraFluoroEthylene is a fluorocarbon-based polymer and is commonly abbreviated PTFE. The Teflon® brand of PTFE is manufactured only by DuPont® and is not sold by Thermacut. Thermacut purchases other brands of PTFE from various high quality manufacturers.

Last update of this page: 30/05/2018. See Revision history for details.

THERMACUT®
THE CUTTING COMPANY®

WWW.THERMACUT.CZ
TEL.: +420 556 423 418
SALES@THERMACUT.CZ

WWW.THERMACUT.DE
TEL.: +49 (0) 27 39 40 33 0
INFO@THERMACUT.DE

WWW.THERMACUT.COM
TEL.: 1-603-542-6715
CUSTOMERSERVICE@THERMACUT.COM

THERMACUT®, THE CUTTING COMPANY®, FHT-EX®, EX-TRAFIRE®, EX-TRACK®, EX-TRABEAM® AND EX-TRAFLEAME® ARE REGISTERED TRADEMARKS OF THERMACUT, K.S. AND MAY BE REGISTERED IN CZECH REPUBLIC AND/OR OTHER COUNTRIES. ALL OTHER TRADEMARKS ARE PROPERTIES OF THEIR RESPECTIVE OWNERS. THERMACUT IS NO WAY AFFILIATED WITH BYSTRONIC® AND E.I. DU PONT DE NEMOURS AND COMPANY. MOST THERMACUT PARTS ARE MADE FOR OR BY AN IBG COMPANY.
VALID FROM JANUARY 2021 • PREVIOUS VERSION IS NO LONGER VALID. • © COPYRIGHT 2021 BY THERMACUT® CZECH REPUBLIC. ALL RIGHTS RESERVED.

**THERMACUT® REPLACEMENT PARTS SUITABLE FOR
BYSTRONIC®
BYSTRONIC® "BY" SERIES**

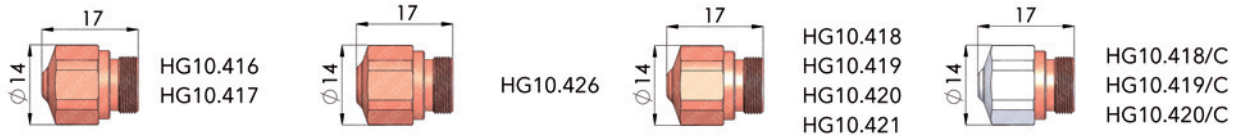

Standard copper nozzles / Standard copper nozzles with hard chromium plating

| Part No. | Ref. No. | Description | Std. Pkg. | Part No. | Ref. No. | Description | Std. Pkg. |
|------------|-----------|----------------------------|-----------|------------|------------|----------------------------|-----------|
| HG10.416 | 3-01908 | Nozzle 1.75mm - K17 | 10pcs | HG10.421/C | 3-01913CP | Nozzle 1.75mm - HK17 - HCP | 10pcs |
| HG10.417 | 3-01909 | Nozzle 2.00mm - K20 | 10pcs | HG10.422 | 3-01914 | Nozzle 2.00mm - HK20 | 10pcs |
| HG10.426 | 3-04274 | Nozzle 2.25mm - K25 | 10pcs | HG10.422/C | 3-01914CP | Nozzle 2.00mm - HK20 - HCP | 10pcs |
| HG10.418 | 3-01910 | Nozzle 1.00mm - HK10 | 10pcs | HG10.423 | 3-03854 | Nozzle 2.5mm - HK25 | 10pcs |
| HG10.418/C | 3-01910CP | Nozzle 1.00mm - HK10 - HCP | 10pcs | HG10.423/C | 3-03854CP | Nozzle 2.5mm - HK25 - HCP | 10pcs |
| HG10.419 | 3-01911 | Nozzle 1.25mm - HK12 | 10pcs | HG10.425 | 3-06112 | Nozzle 3.0mm - HK30 | 10pcs |
| HG10.419/C | 3-01911CP | Nozzle 1.25mm - HK12 - HCP | 10pcs | HG10.425/C | 3-06112CP | Nozzle 3.0mm - HK30 - HCP | 10pcs |
| HG10.420 | 3-01912 | Nozzle 1.50mm - HK15 | 10pcs | HG10.424 | HG10.424 | Nozzle 3.50mm - HK35 | 10pcs |
| HG10.420/C | 3-01912CP | Nozzle 1.50mm - HK15 - HCP | 10pcs | HG10.424/C | HG10.424CP | Nozzle 3.50mm - HK35 - HCP | 10pcs |
| HG10.421 | 3-01913 | Nozzle 1.75mm - HK17 | 10pcs | | | | |



Standard double copper nozzles / Standard double copper nozzles with hard chromium plating

| Part No. | Ref. No. | Description | Std. Pkg. | Part No. | Ref. No. | Description | Std. Pkg. |
|------------|-----------|---------------------------|-----------|------------|-------------|---------------------------------|-----------|
| HG10.428/D | 3-16058 | Nozzle 1.00mm - NK10 | 10pcs | HG10.418/D | 3-16058CP | Nozzle 1.00mm - NK10 - HCP | 10pcs |
| HG10.429/D | 3-16059 | Nozzle 1.20mm - NK12 | 10pcs | HG10.419/D | 3-16059CP | Nozzle 1.20mm - NK12 - HCP | 10pcs |
| HG10.430/D | 3-16060 | Nozzle 1.50mm - NK15 | 10pcs | HG10.420/D | 3-16060CP | Nozzle 1.50mm - NK15 - HCP | 10pcs |
| HG10.431/D | 3-14317 | Nozzle 1.70mm - NK17 | 10pcs | HG10.421/D | 3-14317CP | Nozzle 1.70mm - NK17 - HCP | 10pcs |
| HG10.432/D | 3-14318 | Nozzle 2.00mm - NK20 | 10pcs | HG10.422/D | 3-14318CP | Nozzle 2.00mm - NK20 - HCP | 10pcs |
| HG10.433/D | 3-14319 | Nozzle 2.50mm - NK25 | 10pcs | HG10.423/D | 3-14319CP | Nozzle 2.50mm - NK25 - HCP | 10pcs |
| HG10.433/A | 3-16256 | Nozzle 2.50mm - NK25 - AL | 10pcs | HG10.423/A | 3-16256CP | Nozzle 2.50mm - NK25 - AL - HCP | 10pcs |
| HG10.435/D | 3-16061 | Nozzle 3.00mm - NK30 | 10pcs | HG10.425/D | 3-16061CP | Nozzle 3.00mm - NK30 - HCP | 10pcs |
| HG10.435/A | 3-16257 | Nozzle 3.00mm - NK30 - AL | 10pcs | HG10.425/A | 3-16257CP | Nozzle 3.00mm - NK30 - AL - HCP | 10pcs |
| HG10.434/D | HG10.434D | Nozzle 3.50mm - NK35 | 10pcs | HG10.424/D | HG10.434DCP | Nozzle 3.50mm - NK35 - HCP | 10pcs |

Last update of this page: 30/05/2018. See Revision history for details.

THERMACUT®
THE CUTTING COMPANY®

WWW.THERMACUT.CZ
TEL.: +420 556 423 418
SALES@THERMACUT.CZ

WWW.THERMACUT.DE
TEL.: +49 (0) 27 39 40 33 0
INFO@THERMACUT.DE

WWW.THERMACUT.COM
TEL.: 1-603-542-6715
CUSTOMERSERVICE@THERMACUT.COM

THERMACUT®, THE CUTTING COMPANY®, FHT-EX®, EX-TRAFIRE®, EX-TRACK®, EX-TRABEAM® AND EX-TRAFLEAME® ARE REGISTERED TRADEMARKS OF THERMACUT, K.S. AND MAY BE REGISTERED IN CZECH REPUBLIC AND/OR OTHER COUNTRIES. ALL OTHER TRADEMARKS ARE PROPERTIES OF THEIR RESPECTIVE OWNERS. THERMACUT IS NO WAY AFFILIATED WITH BYSTRONIC®. MOST THERMACUT PARTS ARE MADE FOR OR BY AN IBG COMPANY.

VALID FROM JANUARY 2021 • PREVIOUS VERSION IS NO LONGER VALID. • © COPYRIGHT 2021 BY THERMACUT® CZECH REPUBLIC. ALL RIGHTS RESERVED.

THERMACUT® REPLACEMENT PARTS SUITABLE FOR BYSTRONIC®

LENSES SUITABLE FOR BYSTRONIC®



| Part No. | Ref. No. | Description | Std. Pkg. | Part No. | Ref. No. | Description | Std. Pkg. |
|------------|----------|--|-----------|-------------|----------|--|-----------|
| HG10.730/H | 4-00185 | 3.75" ZnSe Meniscus lens High pressure lens (20bar), 38.1mm Effective focal length: 95.3mm Edge thickness: 6.0mm AR/AR for 10.6µm (absorption <0.20%) | 1pc | HG10.733/H | 4-05094 | 5.00" ZnSe Meniscus lens High pressure lens (42bar), 38.1mm Effective focal length: 127.0mm Edge thickness: 9.0mm AR/AR for 10.6µm (absorption <0.20%) | 1pc |
| HG10.731/H | 4-00186 | 5.00" ZnSe Meniscus lens High pressure lens (20bar), 38.1mm Effective focal length: 127.0mm Edge thickness: 6.0mm AR/AR for 10.6µm (absorption <0.20%) | 1pc | HG10.734/H | 4-05095 | 7.50" ZnSe Meniscus lens High pressure lens (42bar), 38.1mm Effective focal length: 190.5mm Edge thickness: 9.0mm AR/AR for 10.6µm (absorption <0.20%) | 1pc |
| HG10.732/H | 4-00187 | 7.50" ZnSe Meniscus lens High pressure lens (20bar), 38.1mm Effective focal length: 190.5mm Edge thickness: 6.0mm AR/AR for 10.6µm (absorption <0.20%) | 1pc | HG10.733/HU | 4-07475 | 5.00" ZnSe Meniscus lens - ULTRA LOW High pressure lens (42bar), 38.1mm Effective focal length: 127.0mm Edge thickness: 9.0mm AR/AR for 10.6µm (absorption <0.13%) | 1pc |
| HG10.729/H | 4-10736 | 3.75" ZnSe Meniscus lens High pressure lens (42bar), 38.1mm Effective focal length: 95.3mm Edge thickness: 9.0mm AR/AR for 10.6µm (absorption <0.20%) | 1pc | HG10.734/HU | 4-07476 | 7.50" ZnSe Meniscus lens - ULTRA LOW High pressure lens (42bar), 38.1mm Effective focal length: 190.5mm Edge thickness: 9.0mm AR/AR for 10.6µm (absorption <0.13%) | 1pc |

PROTECTION WINDOWS SUITABLE FOR BYSTRONIC®

| Part No. | Ref. No. | Description | Std. Pkg. |
|----------|----------|---|-----------|
| HG17.517 | 10045746 | Protection Window D36.00mm × ET = 5.0mm | 1pc |

ACCESSORIES SUITABLE FOR BYSTRONIC®

| Part No. | Ref. No. | Description | Std. Pkg. |
|----------|----------|---|-----------|
| HG10.174 | HG10.174 | Polish for laser optics, 100ml | 1pc |
| HG10.173 | HG10.173 | Lens cleaning paper from TIFFEN®, sheet size 70 × 115mm | 50pcs |
| HG15.136 | HG15.136 | Latex gloves | 100pcs |

AIR FILTERS SUITABLE FOR BYSTRONIC®

| Part No. | Ref. No. | Description | Std. Pkg. | Part No. | Ref. No. | Description | Std. Pkg. |
|----------|----------|---|-----------|----------|----------|---|-----------|
| HG10.175 | HG10.175 | Air filter for cooling aggregate size: 400 × 600 × 8mm | 25pcs | HG11.179 | HG11.179 | Air filter for cooling aggregate size: 600 × 1200 × 8mm | 25pcs |
| HG10.176 | HG10.176 | Air filter for cooling aggregate size: 800 × 600 × 8mm | 25pcs | HG11.176 | HG11.176 | Air filter for cooling aggregate size: 1050 × 1050 × 8mm | 25pcs |

Last update of this page: 11/11/2017. See Revision history for details.

THERMACUT®
THE CUTTING COMPANY®

WWW.THERMACUT.CZ
TEL.: +420 556 423 418
SALES@THERMACUT.CZ

WWW.THERMACUT.DE
TEL.: +49 (0) 27 39 40 33 0
INFO@THERMACUT.DE

WWW.THERMACUT.COM
TEL.: 1-603-542-6715
CUSTOMERSERVICE@THERMACUT.COM

THERMACUT®, THE CUTTING COMPANY®, FHT-EX®, EX-TRAFIRE®, EX-TRACK®, EX-TRABEAM® AND EX-TRAFLEAME® ARE REGISTERED TRADEMARKS OF THERMACUT, K.S. AND MAY BE REGISTERED IN CZECH REPUBLIC AND/OR OTHER COUNTRIES. ALL OTHER TRADEMARKS ARE PROPERTIES OF THEIR RESPECTIVE OWNERS. THERMACUT IS NO WAY AFFILIATED WITH BYSTRONIC® AND THE TIFFEN COMPANY. MOST THERMACUT PARTS ARE MADE FOR OR BY AN IBG COMPANY.
VALID FROM JANUARY 2021 • PREVIOUS VERSION IS NO LONGER VALID. • © COPYRIGHT 2021 BY THERMACUT® CZECH REPUBLIC. ALL RIGHTS RESERVED.

THERMACUT® REPLACEMENT PARTS SUITABLE FOR CINCINNATI®

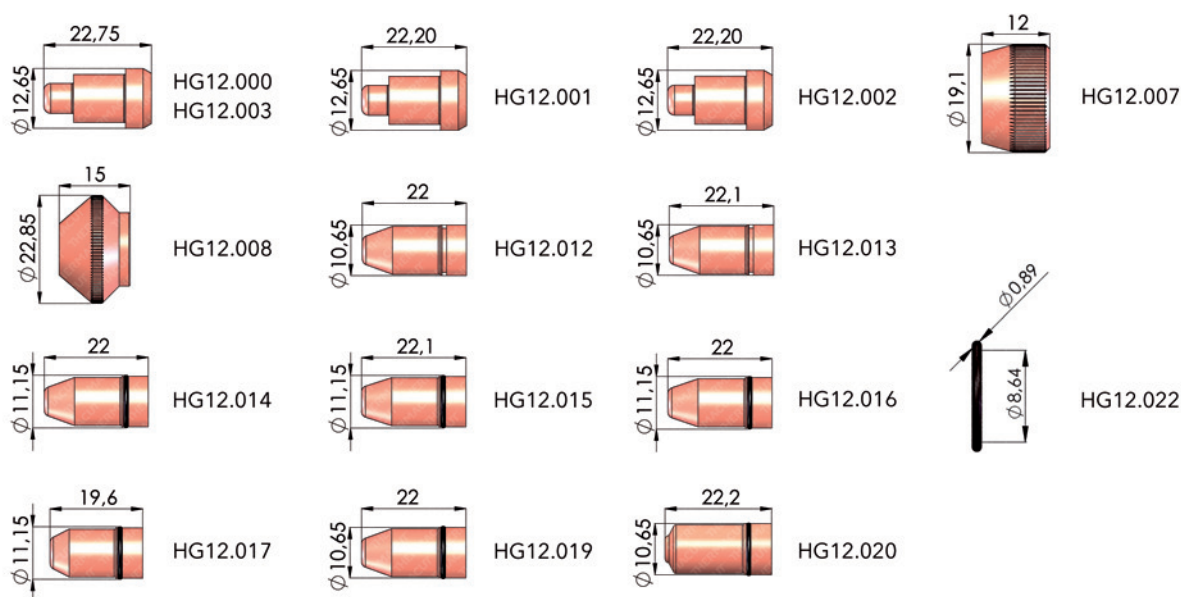

| Part No. | Ref. No. | Description | Std. Pkg. | Part No. | Ref. No. | Description | Std. Pkg. |
|----------|----------|------------------------|-----------|----------|-----------|-----------------------------------|-----------|
| HG12.000 | 908090 | Nozzle 1.5mm (0.060") | 10pcs | HG12.020 | 924636 | Nozzle 1.5mm (0.060") | 10pcs |
| HG12.001 | 907469 | Nozzle 1.0mm (0.040") | 10pcs | HG12.021 | 924637 | Nozzle 2.0mm (0.080") | 10pcs |
| HG12.002 | 907470 | Nozzle 1.5mm (0.060") | 10pcs | HG12.022 | 909680 | O-Ring Kit for Nozzle (10pcs) | 1pc |
| HG12.003 | 920006 | Nozzle 2.0mm (0.080") | 10pcs | HG12.004 | 907677 | Nozzle Holder Contact | 1pc |
| HG12.007 | 909659 | Tip Lock Nut | 1pc | HG12.005 | 907472 | Nozzle Holder Contact with Gasket | 1pc |
| HG12.008 | 963021 | Tip Retainer Nut | 1pc | HG12.006 | HG12006 | Gasket PTFE with Spring | 1pc |
| HG12.012 | 924635-1 | Nozzle 1.0mm (0.040") | 10pcs | HG12.009 | 923258 | Nozzle Body | 1pc |
| HG12.013 | 909660 | Nozzle 1.5mm (0.060") | 10pcs | HG12.010 | 923259 | Insulator Ring | 1pc |
| HG12.014 | 910315 | Nozzle 2.0mm (0.080") | 10pcs | HG12.011 | 909658 | Tip Retainer Extension | 1pc |
| HG12.015 | 924638 | Nozzle 2.5mm (0.100") | 10pcs | HG12.041 | PLGJT0256 | Nozzle Double Blunt 1 | 10pcs |
| HG12.016 | 924634 | Nozzle 3.0mm (0.120") | 10pcs | HG12.042 | PLGJT0257 | Nozzle Double Blunt 1.5 | 10pcs |
| HG12.017 | 924635 | Nozzle 3.15mm (0.124") | 10pcs | HG12.040 | PLGJT0718 | Nozzle Double Blunt 1.5-2.0 | 10pcs |
| HG12.018 | 923013 | Nozzle 1.0mm (0.040") | 10pcs | | | | |
| HG12.019 | 923014 | Nozzle 1.5mm (0.060") | 10pcs | | | | |

PolyTetraFluoroEthylene is a fluorocarbon-based polymer and is commonly abbreviated PTFE. The Teflon® brand of PTFE is manufactured only by DuPont® and is not sold by Thermacut. Thermacut purchases other brands of PTFE from various high quality manufacturers.

Last update of this page: 27/04/2020. See Revision history for details.

THERMACUT®
THE CUTTING COMPANY™

WWW.THERMACUT.CZ
TEL.: +420 556 423 418
SALES@THERMACUT.CZ

WWW.THERMACUT.DE
TEL.: +49 (0) 27 39 40 33 0
INFO@THERMACUT.DE

WWW.THERMACUT.COM
TEL.: 1-603-542-6715
CUSTOMERSERVICE@THERMACUT.COM

THERMACUT®, THE CUTTING COMPANY®, FHT-EX®, EX-TRAFIRE®, EX-TRACK®, EX-TRABEAM® AND EX-TRAFLEAME® ARE REGISTERED TRADEMARKS OF THERMACUT, K.S. AND MAY BE REGISTERED IN CZECH REPUBLIC AND/OR OTHER COUNTRIES. ALL OTHER TRADEMARKS ARE PROPERTIES OF THEIR RESPECTIVE OWNERS. THERMACUT IS NO WAY AFFILIATED WITH CINCINNATI® AND E.I. DU PONT DE NEMOURS AND COMPANY. MOST THERMACUT PARTS ARE MADE FOR OR BY AN IBG COMPANY.
VALID FROM JANUARY 2021 • PREVIOUS VERSION IS NO LONGER VALID. • © COPYRIGHT 2021 BY THERMACUT® CZECH REPUBLIC. ALL RIGHTS RESERVED.

THERMACUT® REPLACEMENT PARTS SUITABLE FOR CINCINNATI® LENSES SUITABLE FOR CINCINNATI®



| Part No. | Ref. No. | Description | Std. Pkg. | Part No. | Ref. No. | Description | Std. Pkg. |
|----------|-----------|--|-----------|----------|-----------|--|-----------|
| HG12.034 | 504211/HU | ZnSe-Plano-Convex Lens FL=5"WD D=2.0" ET=.380" ULTRA LOW | 1pc | HG12.029 | 922376-WD | ZnSe-Plano-Convex Lens FL=7.5"WD D=1.5" ET=.380" | 1pc |
| HG12.023 | 907557 | ZnSe-Plano-Convex Lens FL=5" D=1.5" ET=.160" | 1pc | HG12.026 | 922377 | ZnSe-Plano-Convex Lens FL=5" D=2.0" ET=.380" | 1pc |
| HG12.024 | 908085 | ZnSe-Plano-Convex Lens FL=5"WD D=1.5" ET=.280" | 1pc | HG12.033 | 922377/HU | ZnSe-Plano-Convex Lens FL=5" D=2.0" ET=.380" ULTRA LOW | 1pc |
| HG12.031 | 908085/HU | ZnSe-Plano-Convex Lens FL=5"WD D=1.5" ET=.280" ULTRA LOW | 1pc | HG12.027 | 922377-WD | ZnSe-Plano-Convex Lens FL=5"WD D=2.0" ET=.380" | 1pc |
| HG12.025 | 909484 | ZnSe-Plano-Convex Lens FL=7.5"WD D=1.5" ET=.280" | 1pc | HG12.030 | 926274 | ZnSe-Plano-Convex Lens FL=10"WD D=1.5" ET=.380" | 1pc |
| HG12.032 | 909484/HU | ZnSe-Plano-Convex Lens FL=7.5"WD D=1.5" ET=.315" | 1pc | | | | |
| HG12.028 | 922376 | ZnSe-Plano-Convex Lens FL=7.5" D=1.5" ET=.380" | 1pc | | | | |
| HG12.035 | 922376/HU | ZnSe-Plano-Convex Lens FL=7.5" D=2.0" ET=.380" ULTRA LOW | 1pc | | | | |

PROTECTION WINDOWS SUITABLE FOR CINCINNATI®

| Part No. | Ref. No. | Description | Std. Pkg. |
|----------|----------|--|-----------|
| HG12.036 | HG12.036 | Protection Window D38.10mm × ET = 1.60mm | 1pc |
| HG12.037 | HG12.037 | Protection Window D38.10mm × ET = 6.0mm | 1pc |

Last update of this page: 27/04/2020. See Revision history for details.

THERMACUT®
THE CUTTING COMPANY®

WWW.THERMACUT.CZ
TEL.: +420 556 423 418
SALES@THERMACUT.CZ

WWW.THERMACUT.DE
TEL.: +49 (0) 27 39 40 33 0
INFO@THERMACUT.DE

WWW.THERMACUT.COM
TEL.: 1-603-542-6715
CUSTOMERSERVICE@THERMACUT.COM

THERMACUT®, THE CUTTING COMPANY®, FHT-EX®, EX-TRAFIRE®, EX-TRACK®, EX-TRABEAM® AND EX-TRAFLEAME® ARE REGISTERED TRADEMARKS OF THERMACUT, K.S. AND MAY BE REGISTERED IN CZECH REPUBLIC AND/OR OTHER COUNTRIES. ALL OTHER TRADEMARKS ARE PROPERTIES OF THEIR RESPECTIVE OWNERS. THERMACUT IS NO WAY AFFILIATED WITH CINCINNATI® AND E.I. DU PONT DE NEMOURS AND COMPANY. MOST THERMACUT PARTS ARE MADE FOR OR BY AN IBG COMPANY.
VALID FROM JANUARY 2021 • PREVIOUS VERSION IS NO LONGER VALID. • © COPYRIGHT 2021 BY THERMACUT® CZECH REPUBLIC. ALL RIGHTS RESERVED.

THERMACUT® REPLACEMENT PARTS SUITABLE FOR LVD®

PARTS SUITABLE FOR LVD® LASER

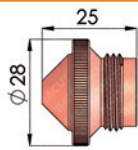

HG10.202
HG10.204
HG10.250

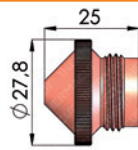

HG10.251

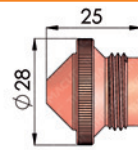

HG10.257
HG10.258

| Part No. | Ref. No. | Description | Std. Pkg. | Part No. | Ref. No. | Description | Std. Pkg. |
|----------|----------|-----------------------------------|-----------|----------|----------|-------------------------------|-----------|
| HG10.202 | D5241993 | Nozzle 0.8mm (inside cylindrical) | 1pc | HG10.259 | D5241862 | Nozzle 1.5mm (inside conical) | 1pc |
| HG10.250 | D7945470 | Nozzle 1.0mm (inside cylindrical) | 1pc | HG10.254 | D5241855 | Nozzle 2.0mm (inside conical) | 1pc |
| HG10.204 | D5241982 | Nozzle 1.2mm (inside cylindrical) | 1pc | HG10.253 | D5241856 | Nozzle 2.5mm (inside conical) | 1pc |
| HG10.251 | D7945434 | Nozzle 1.5mm (inside cylindrical) | 1pc | HG10.255 | D5241857 | Nozzle 3.0mm (inside conical) | 1pc |
| HG10.252 | D7945452 | Nozzle 2.0mm (inside cylindrical) | 1pc | HG10.256 | D5241877 | Nozzle 3.5mm (inside conical) | 1pc |
| HG10.257 | D7945517 | Nozzle 2.5mm (inside cylindrical) | 1pc | HG10.249 | D5241878 | Nozzle 4.0mm (inside conical) | 1pc |
| HG10.258 | D5241863 | Nozzle 1.0mm (inside conical) | 1pc | | | | |
| HG10.203 | HG10.203 | Nozzle 1.2mm (inside conical) | 1pc | | | | |

LENSES SUITABLE FOR LVD®

| Part No. | Ref. No. | Description | Std. Pkg. | Part No. | Ref. No. | Description | Std. Pkg. |
|------------|------------|--|-----------|-------------|-------------|---|-----------|
| HG10.167/H | 29100023 | 5.00" ZnSe Meniscus lens High pressure lens (29bar), 38.1mm Effective focal length: 127.0mm Edge thickness: 7.4mm AR/AR for 10.6µm (absorption <0.20%) | 1pc | HG10.167/HU | 29100023UL | 5.00" ZnSe Men. lens - ULTRA LOW High pressure lens (29bar), 38.1mm Effective focal length: 127.0mm Edge thickness: 7.4mm AR/AR for 10.6µm (absorption <0.13%) | 1pc |
| HG10.168/H | 29100030 | 7.50" ZnSe Meniscus lens High pressure lens (29bar), 38.1mm Effective focal length: 190.5mm Edge thickness: 7.4mm AR/AR for 10.6µm (absorption <0.20%) | 1pc | HG10.168/HU | 29100030UL | 7.50" ZnSe Men. lens - ULTRA LOW High pressure lens (29bar), 38.1mm Effective focal length: 190.5mm Edge thickness: 7.4mm AR/AR for 10.6µm (absorption <0.13%) | 1pc |
| HG10.621/H | 29100055 | 7.50" ZnSe Meniscus lens High pressure lens (28bar), 50.8mm Effective focal length: 190.5mm Edge thickness: 9.7mm AR/AR for 10.6µm (absorption <0.20%) | 1pc | HG10.621/HU | 29100055UL | 7.50" ZnSe Men. lens - ULTRA LOW High pressure lens (29bar), 50.8mm Effective focal length: 190.5mm Edge thickness: 9.7mm AR/AR for 10.6µm (absorption <0.13%) | 1pc |
| HG15.003/H | HG15.003/H | 7.50" ZnSe Plano-convex lens High pressure lens (28bar), 50.8mm Effective focal length: 190.5mm Edge thickness: 9.7mm AR/AR for 10.6µm (absorption <0.20%) | 1pc | HG15.003/HU | HG15.003/HU | 7.50" ZnSe Plano-con. - ULTRA LOW High pressure lens (28bar), 50.8mm Effective focal length: 190.5mm Edge thickness: 9.7mm AR/AR for 10.6µm (absorption <0.13%) | 1pc |
| HG10.622/H | 29100061UL | 10.00" ZnSe Meniscus lens High pressure lens (28bar), 50.8mm Effective focal length: 254.0mm Edge thickness: 9.7mm AR/AR for 10.6µm (absorption <0.20%) | 1pc | HG10.622/HU | 29100061UL | 10.00" ZnSe Men. lens - ULTRA LOW High pressure lens (28bar), 50.8mm Effective focal length: 254.0mm Edge thickness: 9.7mm AR/AR for 10.6µm (absorption <0.13%) | 1pc |

ACCESSORIES SUITABLE FOR LVD®

| Part No. | Ref. No. | Description | Std. Pkg. |
|----------|----------|---|-----------|
| HG10.174 | HG10.174 | Polish for laser optics, 100ml | 1pc |
| HG10.173 | HG10.173 | Lens cleaning paper from TIFFEN®, sheet size 70 × 115mm | 50pcs |

Last update of this page: 02/07/2018. See Revision history for details.

THERMACUT®
THE CUTTING COMPANY™

WWW.THERMACUT.CZ
TEL.: +420 556 423 418
SALES@THERMACUT.CZ

WWW.THERMACUT.DE
TEL.: +49 (0) 27 39 40 33 0
INFO@THERMACUT.DE

WWW.THERMACUT.COM
TEL.: 1-603-542-6715
CUSTOMERSERVICE@THERMACUT.COM

THERMACUT®, THE CUTTING COMPANY®, FHT-EX®, EX-TRAFIRE®, EX-TRACK®, EX-TRABEAM® AND EX-TRAFLEAME® ARE REGISTERED TRADEMARKS OF THERMACUT, K.S. AND MAY BE REGISTERED IN CZECH REPUBLIC AND/OR OTHER COUNTRIES. ALL OTHER TRADEMARKS ARE PROPERTIES OF THEIR RESPECTIVE OWNERS. THERMACUT IS NO WAY AFFILIATED WITH LVD® AND THE TIFFEN COMPANY. MOST THERMACUT PARTS ARE MADE FOR OR BY AN IBG COMPANY.
VALID FROM JANUARY 2021 • PREVIOUS VERSION IS NO LONGER VALID. • © COPYRIGHT 2021 BY THERMACUT® CZECH REPUBLIC. ALL RIGHTS RESERVED.

THERMACUT® REPLACEMENT PARTS SUITABLE FOR MAZAK®

MAZAK® XT510 HI-PRO™, NTX48™, TURBO 10KW™, SUPER TURBO 15KW™, SUPER TURBO 20KW HI-PRO™, SUPER TURBO X510 HI-PRO™

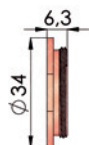

HG10.339

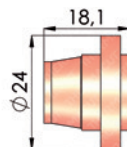

HG10.341

| Part No. | Ref. No. | Description | Std. Pkg. | Part No. | Ref. No. | Description | Std. Pkg. |
|----------|-------------|---------------|-----------|----------|-------------|------------------------|-----------|
| HG10.339 | 46683301100 | Bracket | 1pc | HG10.347 | 46683301160 | Ring | 1pc |
| HG10.341 | 46683300850 | Nozzle Holder | 1pc | HG10.353 | HG10.353 | Complete Nozzle Holder | 1pc |

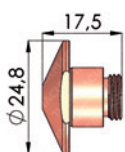

HG10.654

Standard copper nozzles

| Part No. | Ref. No. | Description | Std. Pkg. | Part No. | Ref. No. | Description | Std. Pkg. |
|----------|-----------------|--------------|-----------|----------|-------------|--------------|-----------|
| HG10.651 | 46683301950-1.0 | Nozzle 1.0mm | 10pcs | HG10.657 | 46683301970 | Nozzle 3.0mm | 10pcs |
| HG10.652 | 46683301950-1.2 | Nozzle 1.2mm | 10pcs | HG10.658 | HG10.658 | Nozzle 3.5mm | 10pcs |
| HG10.653 | 46683301950 | Nozzle 1.5mm | 10pcs | HG10.659 | HG10.659 | Nozzle 4.0mm | 10pcs |
| HG10.654 | 46683301821 | Nozzle 2.0mm | 10pcs | | | | |
| HG10.655 | 46683301821-2.2 | Nozzle 2.2mm | 10pcs | | | | |
| HG10.656 | 46683301960 | Nozzle 2.5mm | 10pcs | | | | |

Last update of this page: 30/05/2018. See Revision history for details.

THERMACUT®
THE CUTTING COMPANY®

WWW.THERMACUT.CZ
TEL.: +420 556 423 418
SALES@THERMACUT.CZ

WWW.THERMACUT.DE
TEL.: +49 (0) 27 39 40 33 0
INFO@THERMACUT.DE

WWW.THERMACUT.COM
TEL.: 1-603-542-6715
CUSTOMERSERVICE@THERMACUT.COM

THERMACUT®, THE CUTTING COMPANY®, FHT-EX®, EX-TRAFIRE®, EX-TRACK®, EX-TRABEAM® AND EX-TRAFLEAME® ARE REGISTERED TRADEMARKS OF THERMACUT, K.S. AND MAY BE REGISTERED IN CZECH REPUBLIC AND/OR OTHER COUNTRIES. ALL OTHER TRADEMARKS ARE PROPERTIES OF THEIR RESPECTIVE OWNERS. THERMACUT IS NO WAY AFFILIATED WITH MAZAK®. MOST THERMACUT PARTS ARE MADE FOR OR BY AN IBG COMPANY.

VALID FROM JANUARY 2021 • PREVIOUS VERSION IS NO LONGER VALID. • © COPYRIGHT 2021 BY THERMACUT® CZECH REPUBLIC. ALL RIGHTS RESERVED.

THERMACUT® REPLACEMENT PARTS SUITABLE FOR MAZAK®

MAZAK® LASER CNC L32 PLUS SUPER CHARGE™, XT510™, NTX48™, TURBO 10KW™, SUPER TURBO 15KW™, SUPER TURBO 20KW HI-PRO™, SUPER TURBO X510 HI-PRO™

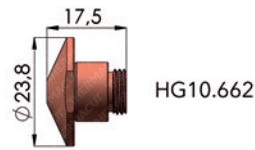
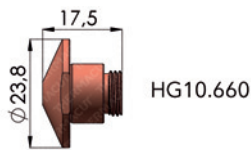

Double copper nozzles

| Part No. | Ref. No. | Description | Std. Pkg. | Part No. | Ref. No. | Description | Std. Pkg. |
|----------|----------|---------------------|-----------|----------|----------|---------------------|-----------|
| HG10.660 | HG10.660 | Double-Nozzle 1.0mm | 10pcs | HG10.664 | HG10.664 | Double-Nozzle 2.2mm | 10pcs |
| HG10.661 | HG10.661 | Double-Nozzle 1.2mm | 10pcs | HG10.665 | HG10.665 | Double-Nozzle 2.5mm | 10pcs |
| HG10.662 | HG10.662 | Double-Nozzle 1.5mm | 10pcs | HG10.666 | HG10.666 | Double-Nozzle 3.0mm | 10pcs |
| HG10.663 | HG10.663 | Double-Nozzle 2.0mm | 10pcs | | | | |

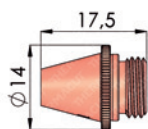

HG10.307

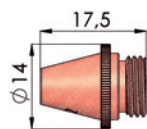

HG10.309
HG10.326

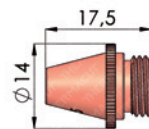

HG10.310

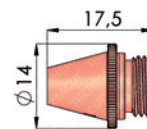

HG10.324
HG10.308

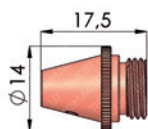

HG10.318

Adapter copper nozzles

| Part No. | Ref. No. | Description | Std. Pkg. | Part No. | Ref. No. | Description | Std. Pkg. |
|----------|--------------|----------------------|-----------|----------|--------------|----------------------------|-----------|
| HG10.323 | 46603350508K | Adapter Nozzle 0.8mm | 10pcs | HG10.475 | 46603350508H | Adapter-6-edgenozzle 0.8mm | 10pcs |
| HG10.307 | 46603350511K | Adapter Nozzle 1.0mm | 10pcs | HG10.476 | 46603350511H | Adapter-6-edgenozzle 1.0mm | 10pcs |
| HG10.309 | 46603350512K | Adapter Nozzle 1.2mm | 10pcs | HG10.477 | 46603350512H | Adapter-6-edgenozzle 1.2mm | 10pcs |
| HG10.310 | 46603350515K | Adapter Nozzle 1.5mm | 10pcs | HG10.478 | 46603350515H | Adapter-6-edgenozzle 1.5mm | 10pcs |
| HG10.324 | 46603350517K | Adapter Nozzle 1.7mm | 10pcs | HG10.479 | 46603350517H | Adapter-6-edgenozzle 1.7mm | 10pcs |
| HG10.318 | 46603350520K | Adapter Nozzle 2.0mm | 10pcs | HG10.480 | 46603350520H | Adapter-6-edgenozzle 2.0mm | 10pcs |
| HG10.308 | 46603350525K | Adapter Nozzle 2.5mm | 10pcs | HG10.481 | 46603350525H | Adapter-6-edgenozzle 2.5mm | 10pcs |
| HG10.325 | 46603350530K | Adapter Nozzle 3.0mm | 10pcs | HG10.482 | 46603350530H | Adapter-6-edgenozzle 3.0mm | 10pcs |
| HG10.303 | 46603350535K | Adapter Nozzle 3.5mm | 10pcs | | | | |
| HG10.326 | 46603350540K | Adapter Nozzle 4.0mm | 10pcs | | | | |

Last update of this page: 02/07/2018. See Revision history for details.

THERMACUT®
THE CUTTING COMPANY®

WWW.THERMACUT.CZ
TEL.: +420 556 423 418
SALES@THERMACUT.CZ

WWW.THERMACUT.DE
TEL.: +49 (0) 27 39 40 33 0
INFO@THERMACUT.DE

WWW.THERMACUT.COM
TEL.: 1-603-542-6715
CUSTOMERSERVICE@THERMACUT.COM

THERMACUT®, THE CUTTING COMPANY®, FHT-EX®, EX-TRAFIRE®, EX-TRACK®, EX-TRABEAM® AND EX-TRAFLEAME® ARE REGISTERED TRADEMARKS OF THERMACUT, K.S. AND MAY BE REGISTERED IN CZECH REPUBLIC AND/OR OTHER COUNTRIES. ALL OTHER TRADEMARKS ARE PROPERTIES OF THEIR RESPECTIVE OWNERS. THERMACUT IS NO WAY AFFILIATED WITH MAZAK®. MOST THERMACUT PARTS ARE MADE FOR OR BY AN IBG COMPANY.

VALID FROM JANUARY 2021 • PREVIOUS VERSION IS NO LONGER VALID. • © COPYRIGHT 2021 BY THERMACUT® CZECH REPUBLIC. ALL RIGHTS RESERVED.

**THERMACUT® REPLACEMENT PARTS SUITABLE FOR
MAZAK®
MAZAK® 5" C/MG, MAZAK® 5" H/MG**

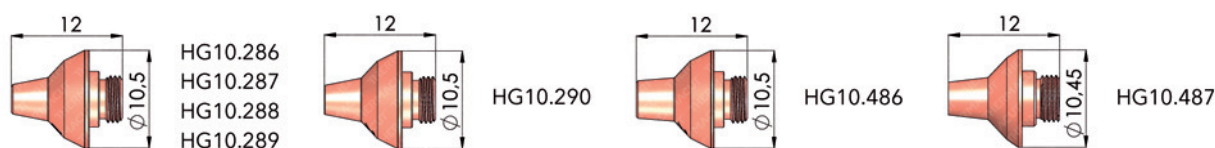

| Part No. | Ref. No. | Description | Std. Pkg. | Part No. | Ref. No. | Description | Std. Pkg. |
|----------|-----------------|-----------------------------------|-----------|----------|-----------------|-----------------------------------|-----------|
| HG10.461 | 4671330032 | Ring for SPACE GEAR VESPEL® | 1pc | HG10.291 | HG10.291 | Nozzle 1.0mm 2D | 1pc |
| HG10.286 | 46713300290-10 | Nozzle 1.0mm 3D (P0352-383-00010) | 1pc | HG10.292 | 46713300310-1.2 | Nozzle 1.2mm 2D | 1pc |
| HG10.287 | 46713300290-12 | Nozzle 1.2mm 3D (P0352-384-00012) | 1pc | HG10.293 | P0352-386-00015 | Nozzle 1.5mm 2D (P0352-386-00015) | 1pc |
| HG10.288 | 46713300290-15 | Nozzle 1.5mm 3D (P0352-381-00015) | 1pc | HG10.294 | HG10.294 | Nozzle 1.8mm 2D | 1pc |
| HG10.289 | HG10.289 | Nozzle 1.8mm 3D | 1pc | HG10.295 | 46713300300 | Nozzle 2.0mm 2D (P0352-387-00020) | 1pc |
| HG10.290 | 46713300310-2.0 | Nozzle 2.0mm 3D (P0352-382-00020) | 1pc | HG10.296 | 46713300300-25 | Nozzle 2.5mm 2D | 1pc |
| HG10.486 | 46713300280-25 | Nozzle 2.5mm 3D (P0352-385-00025) | 1pc | HG10.297 | 46713300300-30 | Nozzle 3.0mm 2D | 1pc |
| HG10.487 | 46713300280-30 | Nozzle 3.0mm 3D | 1pc | | | | |

SUITABLE FOR HYPER GEAR NTX510™



| Part No. | Ref. No. | Description | Std. Pkg. | Part No. | Ref. No. | Description | Std. Pkg. |
|----------|-------------|------------------|-----------|----------|----------|-------------------------|-----------|
| HG10.685 | HG10.685 | Nozzle 1.0mm HCP | 10pcs | HG10.677 | HG10.677 | Double Nozzle 1.2mm HCP | 10pcs |
| HG10.670 | 46143304470 | Nozzle 1.2mm HCP | 10pcs | HG10.678 | HG10.678 | Double Nozzle 1.5mm HCP | 10pcs |
| HG10.671 | 46143304450 | Nozzle 1.5mm HCP | 10pcs | HG10.679 | HG10.679 | Double Nozzle 2.0mm HCP | 10pcs |
| HG10.672 | 46143304460 | Nozzle 2.0mm HCP | 10pcs | HG10.680 | HG10.680 | Double Nozzle 2.5mm HCP | 10pcs |
| HG10.673 | 46143304480 | Nozzle 2.5mm HCP | 10pcs | HG10.681 | HG10.681 | Double Nozzle 3.0mm HCP | 10pcs |
| HG10.674 | 46143304490 | Nozzle 3.0mm HCP | 10pcs | HG10.682 | HG10.682 | Double Nozzle 3.5mm HCP | 10pcs |
| HG10.675 | 46143304500 | Nozzle 3.5mm HCP | 10pcs | HG10.683 | HG10.683 | Double Nozzle 4.0mm HCP | 10pcs |
| HG10.676 | 46143304510 | Nozzle 4.0mm HCP | 10pcs | | | | |

Last update of this page: 30/05/2018. See Revision history for details.

THERMACUT®
THE CUTTING COMPANY®

WWW.THERMACUT.CZ
TEL.: +420 556 423 418
SALES@THERMACUT.CZ

WWW.THERMACUT.DE
TEL.: +49 (0) 27 39 40 33 0
INFO@THERMACUT.DE

WWW.THERMACUT.COM
TEL.: 1-603-542-6715
CUSTOMERSERVICE@THERMACUT.COM

THERMACUT®, THE CUTTING COMPANY®, FHT-EX®, EX-TRAFIRE®, EX-TRACK®, EX-TRABEAM® AND EX-TRAFLEAME® ARE REGISTERED TRADEMARKS OF THERMACUT, K.S. AND MAY BE REGISTERED IN CZECH REPUBLIC AND/OR OTHER COUNTRIES. ALL OTHER TRADEMARKS ARE PROPERTIES OF THEIR RESPECTIVE OWNERS. THERMACUT IS NO WAY AFFILIATED WITH MAZAK® AND E.I. DU PONT DE NEMOURS AND COMPANY. MOST THERMACUT PARTS ARE MADE FOR OR BY AN IBG COMPANY.
VALID FROM JANUARY 2021 • PREVIOUS VERSION IS NO LONGER VALID. • © COPYRIGHT 2021 BY THERMACUT® CZECH REPUBLIC. ALL RIGHTS RESERVED.

THERMACUT® REPLACEMENT PARTS SUITABLE FOR MAZAK®

| Part No. | Ref. No. | Description | Std. Pkg. | Part No. | Ref. No. | Description | Std. Pkg. |
|----------|-------------|-----------------------------|-----------|----------|-------------|-----------------------------|-----------|
| HG10.629 | 36143304420 | Nozzle Holder Hyper Gear | 1pc | HG10.643 | 46683301180 | Screw | 1pc |
| HG10.630 | 36143304400 | Coupler | 1pc | HG10.644 | 46143304440 | Insulator - PTFE | 1pc |
| HG10.631 | 46143300230 | Replacement Ball Kit (6pcs) | 1pc | HG10.645 | 46143300290 | Retainer Nut | 1pc |
| HG10.632 | 46143304430 | Spring Retainer | 1pc | HG10.646 | 46143300260 | Insulator - PTFE | 1pc |
| HG10.633 | 46143308000 | Spring Retainer - Steel | 1pc | HG10.647 | 46143300270 | Insulator - PTFE | 1pc |
| HG10.634 | 46143300220 | Spring | 1pc | HG10.648 | 46143300280 | Retainer Nut | 1pc |
| HG10.635 | 36143303242 | Body | 1pc | HG10.649 | 46143300320 | Ring - Brass | 1pc |
| HG10.636 | 36143307980 | Aluminium Body | 1pc | HG10.667 | 36143300332 | Ring - Aluminum | 1pc |
| HG10.637 | 46603300030 | Screw | 1pc | HG10.668 | HG10.668 | Screw (4pcs) | 1pc |
| HG10.638 | 46143308170 | Spacer | 1pc | HG10.669 | A06CB040200 | Set Screw (4pcs) | 1pc |
| HG10.639 | 46143308190 | Connector | 1pc | HG10.686 | | Complete Head (PTFE Spacer) | 1pc |
| HG10.640 | 46143300240 | Insulator - PTFE | 1pc | HG10.687 | | Complete Head (PTFE Spacer) | 1pc |
| HG10.641 | 46143304250 | Retainer Nut | 1pc | | | | |
| HG10.642 | 46143307420 | Retainer Nut | 1pc | | | | |

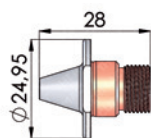

HG10.689-HG10.697

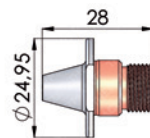

HG10.698, HG10.699

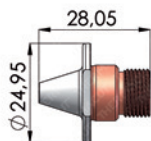

HG10.689/D-HG10.692/D

| Part No. | Ref. No. | Description | Std. Pkg. | Part No. | Ref. No. | Description | Std. Pkg. |
|------------|-------------|-----------------------------|-----------|------------|-----------------|-----------------------------|-----------|
| HG10.689 | | Nozzle 0.8mm Slim CP | 10pcs | HG10.694/D | 36143311510 | Nozzle 2.0mm Slim Double CP | 10pcs |
| HG10.690 | | Nozzle 1.0mm Slim CP | 10pcs | HG10.695/D | | Nozzle 2.2mm Slim Double CP | 10pcs |
| HG10.691 | 46143310341 | Nozzle 1.2mm Slim CP | 10pcs | HG10.696/D | 36143311520 | Nozzle 2.5mm Slim Double CP | 10pcs |
| HG10.692 | 46143310351 | Nozzle 1.5mm Slim CP | 10pcs | HG10.697/D | 36143311530 | Nozzle 3.0mm Slim Double CP | 10pcs |
| HG10.693 | | Nozzle 1.8mm Slim CP | 10pcs | HG10.698/D | | Nozzle 3.5mm Slim Double CP | 10pcs |
| HG10.694 | 46143310361 | Nozzle 2.0mm Slim CP | 10pcs | HG10.705 | 46603350521-0.8 | Nozzle 0.8mm | 10pcs |
| HG10.695 | | Nozzle 2.2mm Slim CP | 10pcs | HG10.706 | 46603350521-1.0 | Nozzle 1.0mm | 10pcs |
| HG10.696 | 46143310371 | Nozzle 2.5mm Slim CP | 10pcs | HG10.707 | 46603350521-1.2 | Nozzle 1.2mm | 10pcs |
| HG10.697 | 46143310381 | Nozzle 3.0mm Slim CP | 10pcs | HG10.708 | 46603350520-1.5 | Nozzle 1.5mm | 10pcs |
| HG10.698 | 46143310392 | Nozzle 3.5mm Slim CP | 10pcs | HG10.709 | 46603350521-1.7 | Nozzle 1.7mm | 10pcs |
| HG10.699 | 46143310401 | Nozzle 4.0mm Slim CP | 10pcs | HG10.710 | 46603350522-2.0 | Nozzle 2.0mm | 10pcs |
| HG10.689/D | HG10.689DCP | Nozzle 0.8mm Slim Double CP | 10pcs | HG10.711 | 46603350522-2.5 | Nozzle 2.5mm | 10pcs |
| HG10.690/D | HG10.690DCP | Nozzle 1.0mm Slim Double CP | 10pcs | HG10.712 | 46683301281-3.0 | Nozzle 3.0mm | 10pcs |
| HG10.691/D | HG10.691DCP | Nozzle 1.2mm Slim Double CP | 10pcs | | | | |
| HG10.692/D | 36143311500 | Nozzle 1.5mm Slim Double CP | 10pcs | | | | |
| HG10.693/D | | Nozzle 1.8mm Slim Double CP | 10pcs | | | | |

PolyTetraFluoroEthylene is a fluorocarbon-based polymer and is commonly abbreviated PTFE. The Teflon® brand of PTFE is manufactured only by DuPont® and is not sold by Thermacut. Thermacut purchases other brands of PTFE from various high quality manufacturers.

Last update of this page: 21/07/2020. See Revision history for details.

THERMACUT®
THE CUTTING COMPANY™

WWW.THERMACUT.CZ
TEL.: +420 556 423 418
SALES@THERMACUT.CZ

WWW.THERMACUT.DE
TEL.: +49 (0) 27 39 40 33 0
INFO@THERMACUT.DE

WWW.THERMACUT.COM
TEL.: 1-603-542-6715
CUSTOMERSERVICE@THERMACUT.COM

THERMACUT®, THE CUTTING COMPANY®, FHT-EX®, EX-TRAFIRE®, EX-TRACK®, EX-TRABEAM® AND EX-TRAFLEAME® ARE REGISTERED TRADEMARKS OF THERMACUT, K.S. AND MAY BE REGISTERED IN CZECH REPUBLIC AND/OR OTHER COUNTRIES. ALL OTHER TRADEMARKS ARE PROPERTIES OF THEIR RESPECTIVE OWNERS. THERMACUT IS NO WAY AFFILIATED WITH MAZAK® AND E.I. DU PONT DE NEMOURS AND COMPANY. MOST THERMACUT PARTS ARE MADE FOR OR BY AN IBG COMPANY.

VALID FROM JANUARY 2021 • PREVIOUS VERSION IS NO LONGER VALID. • © COPYRIGHT 2021 BY THERMACUT® CZECH REPUBLIC. ALL RIGHTS RESERVED.

THERMACUT® REPLACEMENT PARTS SUITABLE FOR MAZAK®
LENSES SUITABLE FOR MAZAK®



| Part No. | Ref. No. | Description | Std. Pkg. | Part No. | Ref. No. | Description | Std. Pkg. |
|------------|------------|---|-----------|-------------|-------------|--|-----------|
| HG10.167/H | HG10.167/H | 5.00" ZnSe Meniscus lens High pressure lens (29bar), 38.1mm Effective focal length: 127.0mm Edge thickness: 7.4mm AR/AR for 10.6µm (absorption <0.20%) | 1pc | HG15.016/H | HG15.016/H | 7.50" ZnSe Plano-convex lens High pressure lens (29bar), 38.1mm Effective focal length: 190.5mm Edge thickness: 7.6mm AR/AR for 10.6µm (absorption <0.20%) | 1pc |
| HG10.620/H | HG10.620/H | 5.00" ZnSe Meniscus lens High pressure lens (28bar), 50.8mm Effective focal length: 127.0mm Edge thickness: 9.7mm AR/AR for 10.6µm (absorption <0.20%) | 1pc | HG10.621/H | HG10.621/H | 7.50" ZnSe Meniscus lens High pressure lens (28bar), 50.8mm Effective focal length: 190.5mm Edge thickness: 9.7mm AR/AR for 10.6µm (absorption <0.20%) | 1pc |
| HG15.015/H | HG15.015/H | 5.00" ZnSe Plano-convex lens High pressure lens (28bar), 38.1mm Effective focal length: 127.0mm Edge thickness: 7.6mm AR/AR for 10.6µm (absorption <0.20%) | 1pc | HG15.028/H | HG15.028/H | 7.50" ZnSe Plano-convex lens High pressure lens (19bar), 50.8mm Effective focal length: 190.5mm Edge thickness: 7.87mm AR/AR for 10.6µm (absorption <0.20%) | 1pc |
| HG15.024/H | HG15.024/H | 5.00" ZnSe Plano-convex lens High pressure lens (33bar), 38.1mm Effective focal length: 127.0mm Edge thickness: 7.87mm AR/AR for 10.6µm (absorption <0.20%) | 1pc | HG15.003/H | HG15.003/H | 7.50" ZnSe Plano-convex lens High pressure lens (28bar), 50.8mm Effective focal length: 190.5mm Edge thickness: 9.7mm AR/AR for 10.6µm (absorption <0.20%) | 1pc |
| HG15.029/H | HG15.029/H | 5.00" ZnSe Plano-convex lens High pressure lens (19bar), 50.8mm Effective focal length: 127.0mm Edge thickness: 7.87mm AR/AR for 10.6µm (absorption <0.20%) | 1pc | HG10.622/H | HG10.622/H | 10.00" ZnSe Meniscus lens High pressure lens (28bar), 50.8mm Effective focal length: 254.0mm Edge thickness: 9.7mm AR/AR for 10.6µm (absorption <0.20%) | 1pc |
| HG15.002/H | HG15.002/H | 5.00" ZnSe Plano-convex lens High pressure lens (28bar), 50.8mm Effective focal length: 127.0mm Edge thickness: 9.7mm AR/AR for 10.6µm (absorption <0.20%) | 1pc | HG10.167/HU | HG10.167/HU | 5.00" ZnSe Men. lens - ULTRA LOW High pressure lens (29bar), 38.1mm Effective focal length: 127.0mm Edge thickness: 7.4mm AR/AR for 10.6µm (absorption <0.13%) | 1pc |
| HG10.168/H | HG10.168/H | 7.50" ZnSe Meniscus lens High pressure lens (29bar), 38.1mm Effective focal length: 190.5mm Edge thickness: 7.4mm AR/AR for 10.6µm (absorption <0.20%) | 1pc | HG10.168/HU | HG10.168/HU | 7.50" ZnSe Men. lens - ULTRA LOW High pressure lens (29bar), 38.1mm Effective focal length: 190.5mm Edge thickness: 7.4mm AR/AR for 10.6µm (absorption <0.13%) | 1pc |

ACCESSORIES SUITABLE FOR MAZAK®

| Part No. | Ref. No. | Description | Std. Pkg. |
|----------|----------|---|-----------|
| HG10.174 | HG10.174 | Polish for laser optics, 100ml | 1pc |
| HG10.173 | HG10.173 | Lens cleaning paper from TIFFEN®, sheet size 70 × 115mm | 50pcs |

Last update of this page: 02/01/2017. See Revision history for details.

THERMACUT®
THE CUTTING COMPANY®

WWW.THERMACUT.CZ
TEL.: +420 556 423 418
SALES@THERMACUT.CZ

WWW.THERMACUT.DE
TEL.: +49 (0) 27 39 40 33 0
INFO@THERMACUT.DE

WWW.THERMACUT.COM
TEL.: 1-603-542-6715
CUSTOMERSERVICE@THERMACUT.COM

THERMACUT®, THE CUTTING COMPANY®, FHT-EX®, EX-TRAFIRE®, EX-TRACK®, EX-TRABEAM® AND EX-TRAFLEAME® ARE REGISTERED TRADEMARKS OF THERMACUT, K.S. AND MAY BE REGISTERED IN CZECH REPUBLIC AND/OR OTHER COUNTRIES. ALL OTHER TRADEMARKS ARE PROPERTIES OF THEIR RESPECTIVE OWNERS. THERMACUT IS NO WAY AFFILIATED WITH MAZAK® AND THE TIFFEN COMPANY. MOST THERMACUT PARTS ARE MADE FOR OR BY AN IBG COMPANY.

VALID FROM JANUARY 2021 • PREVIOUS VERSION IS NO LONGER VALID. • © COPYRIGHT 2021 BY THERMACUT® CZECH REPUBLIC. ALL RIGHTS RESERVED.

THERMACUT® REPLACEMENT PARTS SUITABLE FOR MITSUBISHI®

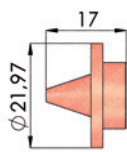

HG12.500
HG12.528

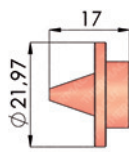

HG12.501

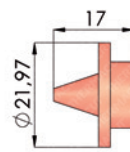

HG12.502

Double copper inserts

| Part No. | Ref. No. | Description | Std. Pkg. | Part No. | Ref. No. | Description | Std. Pkg. |
|----------|----------|-------------------------------|-----------|----------|----------|-------------------------------|-----------|
| HG12.500 | W390 | Double Nozzle Insert 4-holes | 10pcs | HG12.503 | W388 | Double Nozzle Insert 16-holes | 10pcs |
| HG12.528 | W270-6 | Double Nozzle Insert 6-holes | 10pcs | HG12.529 | W389 | Double Nozzle Insert 20-holes | 10pcs |
| HG12.501 | W270 | Double Nozzle Insert 8-holes | 10pcs | HG12.504 | W515 | Double Nozzle Insert 24-holes | 10pcs |
| HG12.502 | W387 | Double Nozzle Insert 12-holes | 10pcs | HG12.505 | W269 | Double Nozzle | 1pc |

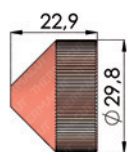

HG12.540
HG12.541
HG12.543–HG12.545

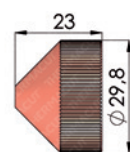

HG12.542
HG12.560–HG12.563

| Part No. | Ref. No. | Description | Std. Pkg. | Part No. | Ref. No. | Description | Std. Pkg. |
|----------|----------|----------------------------|-----------|----------|----------|----------------------------|-----------|
| HG12.540 | W1626 | Nozzle 1.0mm | 10pcs | HG12.546 | W1630 | Nozzle 2.5mm | 10pcs |
| HG12.560 | W1626B | Nozzle 1.0mm, Low Pressure | 10pcs | HG12.564 | W1630B | Nozzle 2.5mm, Low Pressure | 10pcs |
| HG12.541 | W1627 | Nozzle 1.2mm | 1pc | HG12.550 | W1664 | Nozzle 3.0mm | 1pc |
| HG12.542 | W1627B | Nozzle 1.2mm, Low Pressure | 10pcs | HG12.565 | W1664B | Nozzle 3.0mm, Low Pressure | 10pcs |
| HG12.543 | W1628 | Nozzle 1.5mm | 10pcs | HG12.551 | W1665 | Nozzle 3.5mm | 10pcs |
| HG12.561 | W1628B | Nozzle 1.5mm, Low Pressure | 10pcs | HG12.566 | W1665B | Nozzle 3.5mm, Low Pressure | 10pcs |
| HG12.544 | W1661 | Nozzle 1.7mm | 10pcs | HG12.552 | W1666 | Nozzle 4.0mm | 10pcs |
| HG12.562 | W1661B | Nozzle 1.7mm, Low Pressure | 10pcs | HG12.567 | W1666B | Nozzle 4.0mm, Low Pressure | 10pcs |
| HG12.545 | W1629 | Nozzle 2.0mm | 10pcs | HG12.553 | W1663 | Nozzle 5.0mm | 1pc |
| HG12.563 | W1629B | Nozzle 2.0mm, Low Pressure | 10pcs | | | | |

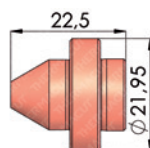

HG12.506
HG12.507
HG12.521

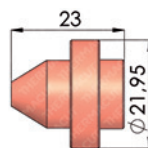

HG12.508

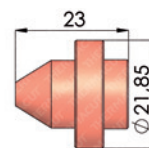

HG12.509

| Part No. | Ref. No. | Description | Std. Pkg. | Part No. | Ref. No. | Description | Std. Pkg. |
|----------|--------------|--------------|-----------|----------|------------|-------------------------|-----------|
| HG12.506 | BQ943D897H01 | Nozzle 1.0mm | 10pcs | HG12.532 | 71800016A0 | Nozzle 1.0mm | 10pcs |
| HG12.507 | BQ943D157H01 | Nozzle 1.5mm | 10pcs | HG12.520 | W777 | Nozzle 1.2mm | 10pcs |
| HG12.508 | BQ943D157H02 | Nozzle 2.0mm | 10pcs | HG12.530 | HG12.530 | Nozzle Nut Short (15mm) | 1pc |
| HG12.509 | BQ943D157H03 | Nozzle 2.5mm | 10pcs | | | | |
| HG12.521 | BQ943D596H01 | Nozzle 3.5mm | 10pcs | | | | |
| HG12.522 | W268-4.0 | Nozzle 4.0mm | 10pcs | | | | |

Last update of this page: 21/07/2020. See Revision history for details.

THERMACUT®
THE CUTTING COMPANY®

WWW.THERMACUT.CZ
TEL.: +420 556 423 418
SALES@THERMACUT.CZ

WWW.THERMACUT.DE
TEL.: +49 (0) 27 39 40 33 0
INFO@THERMACUT.DE

WWW.THERMACUT.COM
TEL.: 1-603-542-6715
CUSTOMERSERVICE@THERMACUT.COM

THERMACUT®, THE CUTTING COMPANY®, FHT-EX®, EX-TRAFIRE®, EX-TRACK®, EX-TRABEAM® AND EX-TRAFLEAME® ARE REGISTERED TRADEMARKS OF THERMACUT, K.S. AND MAY BE REGISTERED IN CZECH REPUBLIC AND/OR OTHER COUNTRIES. ALL OTHER TRADEMARKS ARE PROPERTIES OF THEIR RESPECTIVE OWNERS. THERMACUT IS NO WAY AFFILIATED WITH MITSUBISHI®. MOST THERMACUT PARTS ARE MADE FOR OR BY AN IBG COMPANY.

VALID FROM JANUARY 2021 • PREVIOUS VERSION IS NO LONGER VALID. • © COPYRIGHT 2021 BY THERMACUT® CZECH REPUBLIC. ALL RIGHTS RESERVED.

THERMACUT® REPLACEMENT PARTS SUITABLE FOR MITSUBISHI® LENSES SUITABLE FOR MITSUBISHI®



| Part No. | Ref. No. | Description | Std. Pkg. | Part No. | Ref. No. | Description | Std. Pkg. |
|-------------|------------|---|-----------|-------------|------------|--|-----------|
| HG15.015/H | W500 | 5.00" ZnSe Plano-convex lens High pressure lens (29bar), 38.1mm Effective focal length: 127.0mm Edge thickness: 7.6mm AR/AR for 10.6µm (absorption <0.20%) | 1pc | HG15.029/H | HG15.029/H | 5.00" ZnSe Plano-convex lens High pressure lens (19bar), 50.8mm Effective focal length: 127.0mm Edge thickness: 7.87mm AR/AR for 10.6µm (absorption <0.20%) | 1pc |
| HG15.024/H | W505 | 5.00" ZnSe Plano-convex lens High pressure lens (33bar), 38.1mm Effective focal length: 127.0mm Edge thickness: 7.87mm AR/AR for 10.6µm (absorption <0.20%) | 1pc | HG15.002/H | W813 | 5.00" ZnSe Plano-convex lens High pressure lens (28bar), 50.8mm Effective focal length: 127.0mm Edge thickness: 9.7mm AR/AR for 10.6µm (absorption <0.20%) | 1pc |
| HG15.028/H | W510 | 5.00" ZnSe Plano-convex lens High pressure lens (19bar), 50.8mm Effective focal length: 190.5mm Edge thickness: 7.87mm AR/AR for 10.6µm (absorption <0.20%) | 1pc | HG15.029/HU | W505 | 5.00" ZnSe Plan.-con. - ULTRA LOW High pressure lens (19bar), 50.8mm Effective focal length: 127.0mm Edge thickness: 7.87mm AR/AR for 10.6µm (absorption <0.13%) | 1pc |
| HG15.016/H | HG15.016/H | 7.50" ZnSe Plano-convex lens High pressure lens (29bar), 38.1mm Effective focal length: 190.5mm Edge thickness: 7.6mm AR/AR for 10.6µm (absorption <0.20%) | 1pc | HG15.002/HU | W813 | 5.00" ZnSe Plan.-con. - ULTRA LOW High pressure lens (19bar), 50.8mm Effective focal length: 127.0mm Edge thickness: 9.7mm AR/AR for 10.6µm (absorption <0.13%) | 1pc |
| HG15.003/H | W015 | 7.50" ZnSe Plano-convex lens High pressure lens (29bar), 50.8mm Effective focal length: 190.5mm Edge thickness: 9.7mm AR/AR for 10.6µm (absorption <0.20%) | 1pc | HG15.028/HU | W510UL | 7.50" ZnSe Plan.-con. - ULTRA LOW High pressure lens (19bar), 50.8mm Effective focal length: 190.5mm Edge thickness: 7.87mm AR/AR for 10.6µm (absorption <0.13%) | 1pc |
| HG15.015/HU | W500 | 5.00" ZnSe Plan.-con. - ULTRA LOW High pressure lens (29bar), 38.1mm Effective focal length: 127.0mm Edge thickness: 7.6mm AR/AR for 10.6µm (absorption <0.13%) | 1pc | HG15.003/HU | W015UL | 7.50" ZnSe Plan.-con. - ULTRA LOW High pressure lens (28bar), 50.8mm Effective focal length: 190.5mm Edge thickness: 9.7mm AR/AR for 10.6µm (absorption <0.13%) | 1pc |

ACCESSORIES SUITABLE FOR MITSUBISHI®

| Part No. | Ref. No. | Description | Std. Pkg. |
|----------|----------|---|-----------|
| HG10.174 | HG10.174 | Polish for laser optics, 100ml | 1pc |
| HG10.173 | HG10.173 | Lens cleaning paper from TIFFEN®, sheet size 70 × 115mm | 50pcs |
| HG15.136 | HG15.136 | Latex gloves | 100pcs |

Last update of this page: 11/11/2017. See Revision history for details.

THERMACUT®
THE CUTTING COMPANY™

WWW.THERMACUT.CZ
TEL.: +420 556 423 418
SALES@THERMACUT.CZ

WWW.THERMACUT.DE
TEL.: +49 (0) 27 39 40 33 0
INFO@THERMACUT.DE

WWW.THERMACUT.COM
TEL.: 1-603-542-6715
CUSTOMERSERVICE@THERMACUT.COM

THERMACUT®, THE CUTTING COMPANY®, FHT-EX®, EX-TRAFIRE®, EX-TRACK®, EX-TRABEAM® AND EX-TRAFLEAME® ARE REGISTERED TRADEMARKS OF THERMACUT, K.S. AND MAY BE REGISTERED IN CZECH REPUBLIC AND/OR OTHER COUNTRIES. ALL OTHER TRADEMARKS ARE PROPERTIES OF THEIR RESPECTIVE OWNERS. THERMACUT IS NO WAY AFFILIATED WITH MITSUBISHI® AND THE TIFFEN COMPANY. MOST THERMACUT PARTS ARE MADE FOR OR BY AN IBG COMPANY.
VALID FROM JANUARY 2021 • PREVIOUS VERSION IS NO LONGER VALID. • © COPYRIGHT 2021 BY THERMACUT® CZECH REPUBLIC. ALL RIGHTS RESERVED.

THERMACUT® REPLACEMENT PARTS SUITABLE FOR Precitec®

Precitec® (Weidmüller®), ADIGE® SALA, ESAB®, GHT™, HACO®, BALLIU™,
FINN-POWER®, CR electronic®, MESSER-GRIESHEIM®

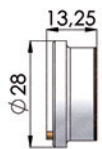

HG11.100

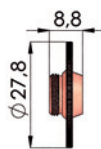

HG11.139

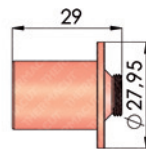

HG11.160

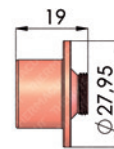

HG11.161

| Part No. | Ref. No. | Description | Std. Pkg. | Part No. | Ref. No. | Description | Std. Pkg. |
|----------|------------------|---|-----------|----------|--------------|--|-----------|
| HG11.100 | P0571-1051-00001 | Ceramic Nozzle Holder | 1pc | | | Length 19mm - Flatbed | |
| HG11.139 | HG11.139 | Nozzle Adapter for TRUMPF® Flatbed | 1pc | HG11.162 | 004.4312.041 | Nozzle Adapter for TRUMPF® Length 30mm - TLC® | 1pc |
| HG11.160 | 004.4312.040 | Nozzle Adapter for TRUMPF® Length 29mm - Flatbed | 1pc | HG11.163 | 004.4312.034 | Nozzle Adapter for TRUMPF® Length 20mm - TLC® | 1pc |
| HG11.161 | 004.4312.032 | Nozzle Adapter for TRUMPF® | 1pc | | | | |



HG11.120
HG11.125



HG11.121



HG11.122
HG11.123



HG11.124

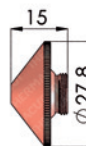

HG11.129
HG11.130
HG11.138

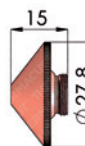

HG11.131-HG11.137
HG11.128



HG11.127
HG11.126

Standard copper nozzles / Double copper nozzles

| Part No. | Ref. No. | Description | Std. Pkg. | Part No. | Ref. No. | Description | Std. Pkg. |
|----------|-----------------|---------------------|-----------|----------|-----------------|---------------------|-----------|
| HG11.120 | P0571-291-00010 | Nozzle 1.0mm | 10pcs | HG11.301 | P0591-002-00012 | Double Nozzle 1.2mm | 10pcs |
| HG11.121 | P0571-292-00012 | Nozzle 1.2mm | 10pcs | HG11.302 | P0591-002-00015 | Double Nozzle 1.5mm | 10pcs |
| HG11.122 | P0571-293-00015 | Nozzle 1.5mm | 10pcs | HG11.303 | P0591-002-00018 | Double Nozzle 1.8mm | 10pcs |
| HG11.123 | P0571-294-00018 | Nozzle 1.8mm | 10pcs | HG11.304 | P0591-002-00020 | Double Nozzle 2.0mm | 10pcs |
| HG11.124 | P0571-295-00020 | Nozzle 2.0mm | 10pcs | HG11.305 | P0591-002-00023 | Double Nozzle 2.3mm | 10pcs |
| HG11.125 | P0571-297-00025 | Nozzle 2.5mm | 10pcs | HG11.306 | P0591-002-00025 | Double Nozzle 2.5mm | 10pcs |
| HG11.129 | P0591-673-00008 | Nozzle 0.8mm | 10pcs | HG11.307 | P0591-002-00030 | Double Nozzle 3.0mm | 10pcs |
| HG11.130 | P0591-571-00010 | Nozzle 1.0mm | 10pcs | HG11.308 | P0591-002-00035 | Double Nozzle 3.5mm | 10pcs |
| HG11.131 | P0591-572-00012 | Nozzle 1.2mm | 10pcs | HG11.150 | P0571-281-00010 | Nozzle 1.0mm | 10pcs |
| HG11.132 | P0591-573-00015 | Nozzle 1.5mm | 10pcs | HG11.151 | P0571-282-00012 | Nozzle 1.2mm | 10pcs |
| HG11.133 | P0591-574-00018 | Nozzle 1.8mm | 10pcs | HG11.152 | P0571-283-00015 | Nozzle 1.5mm | 10pcs |
| HG11.134 | P0591-575-00020 | Nozzle 2.0mm | 10pcs | HG11.153 | HG11.153 | Nozzle 1.8mm | 10pcs |
| HG11.135 | HG11.135 | Nozzle 2.3mm | 10pcs | HG11.154 | P0571-285-00020 | Nozzle 2.0mm | 10pcs |
| HG11.136 | P0591-576-00025 | Nozzle 2.5mm | 10pcs | HG11.155 | HG11.155 | Nozzle 2.2mm | 10pcs |
| HG11.137 | HG11.137 | Nozzle 2.7mm | 10pcs | HG11.156 | P0571-286-00025 | Nozzle 2.5mm | 10pcs |
| HG11.138 | P0591-577-00030 | Nozzle 3.0mm | 10pcs | HG11.157 | HG11.157 | Nozzle 2.7mm | 10pcs |
| HG11.128 | HG11.128 | Nozzle 3.5mm | 10pcs | HG11.158 | HG11.158 | Nozzle 3.0mm | 10pcs |
| HG11.127 | P0591-578-00040 | Nozzle 4.0mm | 10pcs | | | | |
| HG11.126 | P0591-579-00050 | Nozzle 5.0mm | 10pcs | | | | |
| HG11.300 | P0591-002-00010 | Double Nozzle 1.0mm | 10pcs | | | | |

Last update of this page: 11/11/2017. See Revision history for details.

THERMACUT®
THE CUTTING COMPANY®

WWW.THERMACUT.CZ
TEL.: +420 556 423 418
SALES@THERMACUT.CZ

WWW.THERMACUT.DE
TEL.: +49 (0) 27 39 40 33 0
INFO@THERMACUT.DE

WWW.THERMACUT.COM
TEL.: 1-603-542-6715
CUSTOMERSERVICE@THERMACUT.COM

THERMACUT®, THE CUTTING COMPANY®, FHT-EX®, EX-TRAFIRE®, EX-TRACK®, EX-TRABEAM® AND EX-TRAFLEAME® ARE REGISTERED TRADEMARKS OF THERMACUT, K.S. AND MAY BE REGISTERED IN CZECH REPUBLIC AND/OR OTHER COUNTRIES. ALL OTHER TRADEMARKS ARE PROPERTIES OF THEIR RESPECTIVE OWNERS. THERMACUT IS NO WAY AFFILIATED WITH Precitec®, Weidmüller®, ADIGE® SALA, ESAB®, HACO®, FINN-POWER®, CR electronic®, MESSER-GRIESHEIM®, TRUMPF®, TLC®. MOST THERMACUT PARTS ARE MADE FOR OR BY AN IBG COMPANY.

VALID FROM JANUARY 2021 • PREVIOUS VERSION IS NO LONGER VALID. © COPYRIGHT 2021 BY THERMACUT® CZECH REPUBLIC. ALL RIGHTS RESERVED.

THERMACUT® REPLACEMENT PARTS SUITABLE FOR Precitec®

Precitec® (Weidmüller®), ADIGE® SALA, ESAB®, GHT™, HACO®, BALLIU™,
FINN-POWER®, CR electronic®, MESSER-GRIESHEIM®

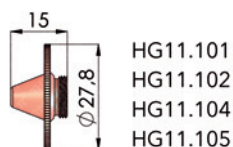

Standard copper nozzles

| Part No. | Ref. No. | Description | Std. Pkg. | Part No. | Ref. No. | Description | Std. Pkg. |
|----------|-----------------|--------------|-----------|----------|-----------------|--------------|-----------|
| HG11.101 | P0591-569-00008 | Nozzle 0.8mm | 10pcs | HG11.107 | HG11.107 | Nozzle 2.2mm | 10pcs |
| HG11.102 | P0591-561-00010 | Nozzle 1.0mm | 10pcs | HG11.108 | P0591-566-00025 | Nozzle 2.5mm | 10pcs |
| HG11.103 | P0591-562-00012 | Nozzle 1.2mm | 10pcs | HG11.109 | HG11.109 | Nozzle 2.7mm | 10pcs |
| HG11.104 | P0591-563-00015 | Nozzle 1.5mm | 10pcs | HG11.110 | P0591-568-00030 | Nozzle 3.0mm | 10pcs |
| HG11.105 | P0591-564-00018 | Nozzle 1.8mm | 10pcs | | | | |
| HG11.106 | P0591-565-00020 | Nozzle 2.0mm | 10pcs | | | | |

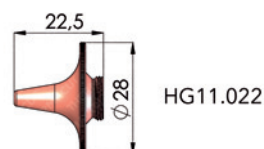
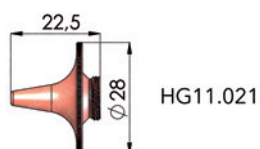
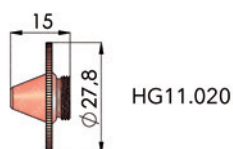

| Part No. | Ref. No. | Description | Std. Pkg. | Part No. | Ref. No. | Description | Std. Pkg. |
|----------|------------------|--------------|-----------|----------|------------------|--------------|-----------|
| HG11.020 | P0578-0411-00010 | Nozzle 1.0mm | 10pcs | HG11.024 | P0578-0415-00020 | Nozzle 2.0mm | 10pcs |
| HG11.021 | P0578-0412-00012 | Nozzle 1.2mm | 10pcs | | | | |
| HG11.022 | P0578-0413-00015 | Nozzle 1.5mm | 10pcs | | | | |
| HG11.023 | P0578-0414-00018 | Nozzle 1.8mm | 10pcs | | | | |

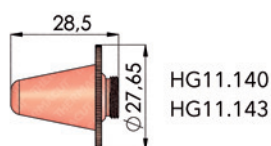

Long copper nozzles

| Part No. | Ref. No. | Description | Std. Pkg. | Part No. | Ref. No. | Description | Std. Pkg. |
|----------|-----------------|-------------------|-----------|----------|-----------------|-------------------|-----------|
| HG11.140 | P0573-563-00010 | Long Nozzle 1.0mm | 10pcs | HG11.144 | P0573-564-00020 | Long Nozzle 2.0mm | 10pcs |
| HG11.141 | P0573-563-00012 | Long Nozzle 1.2mm | 10pcs | HG11.145 | P0573-565-00023 | Long Nozzle 2.3mm | 10pcs |
| HG11.142 | P0573-563-00015 | Long Nozzle 1.5mm | 10pcs | HG11.146 | P0573-566-00025 | Long Nozzle 2.5mm | 10pcs |
| HG11.143 | HG11.143 | Long Nozzle 1.8mm | 10pcs | HG11.147 | HG11.147 | Long Nozzle 3.0mm | 10pcs |

Last update of this page: 02/07/2018. See Revision history for details.

THERMACUT®
THE CUTTING COMPANY®

WWW.THERMACUT.CZ
TEL.: +420 556 423 418
SALES@THERMACUT.CZ

WWW.THERMACUT.DE
TEL.: +49 (0) 27 39 40 33 0
INFO@THERMACUT.DE

WWW.THERMACUT.COM
TEL.: 1-603-542-6715
CUSTOMERSERVICE@THERMACUT.COM

THERMACUT®, THE CUTTING COMPANY®, FHT-EX®, EX-TRAFIRE®, EX-TRACK®, EX-TRABEAM® AND EX-TRAFLEAME® ARE REGISTERED TRADEMARKS OF THERMACUT, K.S. AND MAY BE REGISTERED IN CZECH REPUBLIC AND/OR OTHER COUNTRIES. ALL OTHER TRADEMARKS ARE PROPERTIES OF THEIR RESPECTIVE OWNERS. THERMACUT IS NO WAY AFFILIATED WITH Precitec®, Weidmüller®, ADIGE® SALA, ESAB®, HACO®, FINN-POWER®, CR electronic®, MESSER-GRIESHEIM®. MOST THERMACUT PARTS ARE MADE FOR OR BY AN IBG COMPANY. VALID FROM JANUARY 2021 • PREVIOUS VERSION IS NO LONGER VALID. • © COPYRIGHT 2021 BY THERMACUT® CZECH REPUBLIC. ALL RIGHTS RESERVED.

THERMACUT® REPLACEMENT PARTS SUITABLE FOR Precitec®

Precitec® (Weidmüller®), ADIGE® SALA, ESAB®, GHT™, HACO®, BALLIU™,
FINN-POWER®, CR electronic®, MESSER-GRIESHEIM®

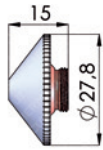

HG11.129/C–HG11.134/C

Standard copper nozzles with chromium plating

| Part No. | Ref. No. | Description | Std. Pkg. | Part No. | Ref. No. | Description | Std. Pkg. |
|------------|-------------------|------------------|-----------|------------|-------------------|------------------|-----------|
| HG11.129/C | P0591-673-00008CP | Nozzle 0.8mm HCP | 10pcs | HG11.135/C | HG11.135CP | Nozzle 2.3mm HCP | 10pcs |
| HG11.130/C | P0591-571-00010CP | Nozzle 1.0mm HCP | 10pcs | HG11.136/C | P0591-576-00025CP | Nozzle 2.5mm HCP | 10pcs |
| HG11.131/C | P0591-572-00012CP | Nozzle 1.2mm HCP | 10pcs | HG11.137/C | HG11.137CP | Nozzle 2.7mm HCP | 10pcs |
| HG11.132/C | P0591-573-00015CP | Nozzle 1.5mm HCP | 10pcs | HG11.138/C | P0591-577-00030CP | Nozzle 3.0mm HCP | 10pcs |
| HG11.133/C | P0591-574-00018CP | Nozzle 1.8mm HCP | 10pcs | HG11.128/C | HG11.128CP | Nozzle 3.5mm HCP | 10pcs |
| HG11.134/C | P0591-575-00020CP | Nozzle 2.0mm HCP | 10pcs | | | | |

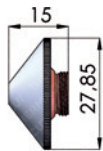

HG11.300/C–HG11.304/C

Double copper nozzles with chromium plating

| Part No. | Ref. No. | Description | Std. Pkg. | Part No. | Ref. No. | Description | Std. Pkg. |
|------------|-------------------|-------------------------|-----------|------------|-------------------|-------------------------|-----------|
| HG11.300/C | P0591-002-00010CP | Double Nozzle 1.0mm HCP | 10pcs | HG11.306/C | P0591-002-00025CP | Double Nozzle 2.5mm HCP | 10pcs |
| HG11.301/C | P0591-002-00012CP | Double Nozzle 1.2mm HCP | 10pcs | HG11.307/C | P0591-002-00030CP | Double Nozzle 3.0mm HCP | 10pcs |
| HG11.302/C | P0591-002-00015CP | Double Nozzle 1.5mm HCP | 10pcs | HG11.308/C | P0591-002-00035CP | Double Nozzle 3.5mm HCP | 10pcs |
| HG11.303/C | P0591-002-00018CP | Double Nozzle 1.8mm HCP | 10pcs | | | | |
| HG11.304/C | P0591-002-00020CP | Double Nozzle 2.0mm HCP | 10pcs | | | | |
| HG11.305/C | P0591-002-00023CP | Double Nozzle 2.3mm HCP | 10pcs | | | | |

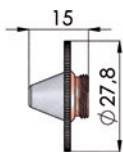

HG11.101/C–HG11.105/C

Standard copper nozzles with chromium plating

| Part No. | Ref. No. | Description | Std. Pkg. | Part No. | Ref. No. | Description | Std. Pkg. |
|------------|-------------------|------------------|-----------|------------|-------------------|------------------|-----------|
| HG11.101/C | P0591-569-00008CP | Nozzle 0.8mm HCP | 10pcs | HG11.107/C | HG11.107CP | Nozzle 2.2mm HCP | 10pcs |
| HG11.102/C | P0591-561-00010CP | Nozzle 1.0mm HCP | 10pcs | HG11.108/C | P0591-566-00025CP | Nozzle 2.5mm HCP | 10pcs |
| HG11.103/C | P0591-562-00012CP | Nozzle 1.2mm HCP | 10pcs | HG11.109/C | HG11.109CP | Nozzle 2.7mm HCP | 10pcs |
| HG11.104/C | P0591-563-00015CP | Nozzle 1.5mm HCP | 10pcs | HG11.110/C | P0591-568-00030CP | Nozzle 3.0mm HCP | 10pcs |
| HG11.105/C | P0591-564-00018CP | Nozzle 1.8mm HCP | 10pcs | | | | |
| HG11.106/C | P0591-565-00020CP | Nozzle 2.0mm HCP | 10pcs | | | | |

Last update of this page: 02/07/2018. See Revision history for details.

THERMACUT®
THE CUTTING COMPANY®

WWW.THERMACUT.CZ
TEL.: +420 556 423 418
SALES@THERMACUT.CZ

WWW.THERMACUT.DE
TEL.: +49 (0) 27 39 40 33 0
INFO@THERMACUT.DE

WWW.THERMACUT.COM
TEL.: 1-603-542-6715
CUSTOMERSERVICE@THERMACUT.COM

THERMACUT®, THE CUTTING COMPANY®, FHT-EX®, EX-TRAFIRE®, EX-TRACK®, EX-TRABEAM® AND EX-TRAFLEAME® ARE REGISTERED TRADEMARKS OF THERMACUT, K.S. AND MAY BE REGISTERED IN CZECH REPUBLIC AND/OR OTHER COUNTRIES. ALL OTHER TRADEMARKS ARE PROPERTIES OF THEIR RESPECTIVE OWNERS. THERMACUT IS NO WAY AFFILIATED WITH Precitec®, Weidmüller®, ADIGE® SALA, ESAB®, HACO®, FINN-POWER®, CR electronic®, MESSER-GRIESHEIM®. MOST THERMACUT PARTS ARE MADE FOR OR BY AN IBG COMPANY. VALID FROM JANUARY 2021 • PREVIOUS VERSION IS NO LONGER VALID. • © COPYRIGHT 2021 BY THERMACUT® CZECH REPUBLIC. ALL RIGHTS RESERVED.

THERMACUT® REPLACEMENT PARTS SUITABLE FOR Precitec® Precitec® (Weidmüller®) 5" KN/MG

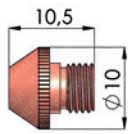

HG10.217
HG10.208
HG10.218

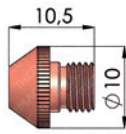

HG10.222

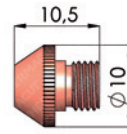

HG10.223

Standard copper nozzels with chromium plating

| Part No. | Ref. No. | Description | Std. Pkg. | Part No. | Ref. No. | Description | Std. Pkg. |
|----------|-----------------|---------------------------------|-----------|----------|----------|---------------------------|-----------|
| HG10.217 | P0494-853-00010 | Nozzle 1.0mm | 10pcs | HG10.225 | HG10.225 | Slop-Cutting Nozzle 1.0mm | 10pcs |
| HG10.208 | P0494-854-00012 | Nozzle 1.2mm | 10pcs | HG10.226 | HG10.226 | Slop-Cutting Nozzle 1.2mm | 10pcs |
| HG10.218 | P0494-855-00015 | Nozzle 1.5mm | 10pcs | HG10.220 | HG10.220 | Slop-Cutting Nozzle 1.4mm | 10pcs |
| HG10.222 | P0494-856-00017 | Nozzle 1.7mm | 10pcs | HG10.221 | HG10.221 | Slop-Cutting Nozzle 1.7mm | 10pcs |
| HG10.223 | P0494-857-00020 | Nozzle 2.0mm | 10pcs | | | | |
| HG10.008 | HG10.008 | Teach Nozzle 0.25mm Rough Edged | 1pc | | | | |

SUITABLE FOR Precitec® DE YR30

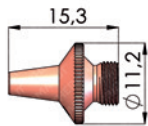

HG11.010
HG11.011
HG11.012

| Part No. | Ref. No. | Description | Std. Pkg. | Part No. | Ref. No. | Description | Std. Pkg. |
|----------|------------------|--------------|-----------|----------|------------------|--------------|-----------|
| HG11.010 | P0787-481-00010 | Nozzle 1.0mm | 10pcs | HG11.014 | P0787-1001-00020 | Nozzle 2.0mm | 10pcs |
| HG11.011 | P0787-482-00012 | Nozzle 1.2mm | 10pcs | | | | |
| HG11.012 | P0787-483-00015 | Nozzle 1.5mm | 10pcs | | | | |
| HG11.013 | P0787-1002-00017 | Nozzle 1.7mm | 10pcs | | | | |

LENSES SUITABLE FOR Precitec®



| Part No. | Ref. No. | Description | Std. Pkg. | Part No. | Ref. No. | Description | Std. Pkg. |
|------------|------------|--|-----------|------------|------------|--|-----------|
| HG10.731/H | HG10.731/H | 5.00" ZnSe Meniscus lens High pressure lens (20bar), 38.1mm Effective focal length: 127.0mm Edge thickness: 6.0mm AR/AR for 10.6µm (absorption <0.20%) | 1pc | HG10.166/H | HG10.166/H | 3.75" ZnSe Meniscus lens High pressure lens (29bar), 38.1mm Effective focal length: 95.3mm Edge thickness: 7.4mm AR/AR for 10.6µm (absorption <0.20%) | 1pc |
| HG10.732/H | HG10.732/H | 7.50" ZnSe Meniscus lens High pressure lens (20bar), 38.1mm Effective focal length: 190.5mm Edge thickness: 6.0mm AR/AR for 10.6µm (absorption <0.20%) | 1pc | HG10.167/H | HG10.167/H | 5.00" ZnSe Meniscus lens High pressure lens (29bar), 38.1mm Effective focal length: 127.0mm Edge thickness: 7.4mm AR/AR for 10.6µm (absorption <0.20%) | 1pc |

Last update of this page: 30/05/2018. See Revision history for details.

THERMACUT®
THE CUTTING COMPANY™

WWW.THERMACUT.CZ
TEL.: +420 556 423 418
SALES@THERMACUT.CZ

WWW.THERMACUT.DE
TEL.: +49 (0) 27 39 40 33 0
INFO@THERMACUT.DE

WWW.THERMACUT.COM
TEL.: 1-603-542-6715
CUSTOMERSERVICE@THERMACUT.COM

THERMACUT®, THE CUTTING COMPANY®, FHT-EX®, EX-TRAFIRE®, EX-TRACK®, EX-TRABEAM® AND EX-TRAFLEAME® ARE REGISTERED TRADEMARKS OF THERMACUT, K.S. AND MAY BE REGISTERED IN CZECH REPUBLIC AND/OR OTHER COUNTRIES. ALL OTHER TRADEMARKS ARE PROPERTIES OF THEIR RESPECTIVE OWNERS. THERMACUT IS NO WAY AFFILIATED WITH Precitec®, Weidmüller®. MOST THERMACUT PARTS ARE MADE FOR OR BY AN IBG COMPANY.
VALID FROM JANUARY 2021 • PREVIOUS VERSION IS NO LONGER VALID. • © COPYRIGHT 2021 BY THERMACUT® CZECH REPUBLIC. ALL RIGHTS RESERVED.

**THERMACUT® REPLACEMENT PARTS SUITABLE FOR
Precitec®
LENSES SUITABLE FOR Precitec®**



| Part No. | Ref. No. | Description | Std. Pkg. | Part No. | Ref. No. | Description | Std. Pkg. |
|-------------|-------------|--|-----------|-------------|-------------|---|-----------|
| HG10.168/H | HG10.168/H | 7.50" ZnSe Meniscus lens High pressure lens (29bar), 38.1mm Effective focal length: 190.5mm Edge thickness: 7.4mm AR/AR for 10.6µm (absorption <0.20%) | 1pc | HG10.168/HU | HG10.168/HU | 7.50" ZnSe Men. lens - ULTRA LOW High pressure lens (29bar), 38.1mm Effective focal length: 190.5mm Edge thickness: 7.4mm AR/AR for 10.6µm (absorption <0.13%) | 1pc |
| HG10.733/H | HG10.733/H | 5.00" ZnSe Meniscus lens High pressure lens (42bar), 38.1mm Effective focal length: 127.0mm Edge thickness: 9.0mm AR/AR for 10.6µm (absorption <0.20%) | 1pc | HG15.003/HU | HG15.003/HU | 7.50" ZnSe Plan.-con. - ULTRA LOW High pressure lens (28bar), 50.8mm Effective focal length: 190.5mm Edge thickness: 9.7mm AR/AR for 10.6µm (absorption <0.13%) | 1pc |
| HG10.734/H | HG10.734/H | 7.50" ZnSe Meniscus lens High pressure lens (42bar), 38.1mm Effective focal length: 190.5mm Edge thickness: 9.0mm AR/AR for 10.6µm (absorption <0.20%) | 1pc | HG10.733/HU | HG10.733/HU | 5.00" ZnSe Men. lens - ULTRA LOW High pressure lens (42bar), 38.1mm Effective focal length: 127.0mm Edge thickness: 9.0mm AR/AR for 10.6µm (absorption <0.13%) | 1pc |
| HG10.620/H | HG10.620/H | 5.00" ZnSe Meniscus lens High pressure lens (42bar), 50.8mm Effective focal length: 127.0mm Edge thickness: 9.7mm AR/AR for 10.6µm (absorption <0.20%) | 1pc | HG10.734/HU | HG10.734/HU | 7.50" ZnSe Men. lens - ULTRA LOW High pressure lens (42bar), 38.1mm Effective focal length: 190.5mm Edge thickness: 9.0mm AR/AR for 10.6µm (absorption <0.13%) | 1pc |
| HG10.621/H | HG10.621/H | 7.50" ZnSe Meniscus lens High pressure lens (28bar), 50.8mm Effective focal length: 190.5mm Edge thickness: 9.7mm AR/AR for 10.6µm (absorption <0.20%) | 1pc | HG10.620/HU | HG10.620/HU | 5.00" ZnSe Men. lens - ULTRA LOW High pressure lens (28bar), 50.8mm Effective focal length: 127.0mm Edge thickness: 9.7mm AR/AR for 10.6µm (absorption <0.13%) | 1pc |
| HG15.002/H | HG15.002/H | 5.00" ZnSe Plano-convex lens High pressure lens (28bar), 50.8mm Effective focal length: 127.0mm Edge thickness: 9.7mm AR/AR for 10.6µm (absorption <0.20%) | 1pc | HG10.621/HU | HG10.621/HU | 7.50" ZnSe Men. lens - ULTRA LOW High pressure lens (28bar), 50.8mm Effective focal length: 190.5mm Edge thickness: 9.7mm AR/AR for 10.6µm (absorption <0.13%) | 1pc |
| HG15.003/H | HG15.003/H | 7.50" ZnSe Plano-convex lens High pressure lens (28bar), 50.8mm Effective focal length: 190.5mm Edge thickness: 9.7mm AR/AR for 10.6µm (absorption <0.20%) | 1pc | HG15.002/HU | HG15.002/HU | 5.00" ZnSe Plan.-con. - ULTRA LOW High pressure lens (28bar), 50.8mm Effective focal length: 127.0mm Edge thickness: 9.7mm AR/AR for 10.6µm (absorption <0.13%) | 1pc |
| HG10.167/HU | HG10.167/HU | 5.00" ZnSe Men. lens - ULTRA LOW High pressure lens (29bar), 38.1mm Effective focal length: 127.0mm Edge thickness: 7.4mm AR/AR for 10.6µm (absorption <0.13%) | 1pc | | | | |

Last update of this page: 28/02/2019. See Revision history for details.

THERMACUT®
THE CUTTING COMPANY™

WWW.THERMACUT.CZ
TEL.: +420 556 423 418
SALES@THERMACUT.CZ

WWW.THERMACUT.DE
TEL.: +49 (0) 27 39 40 33 0
INFO@THERMACUT.DE

WWW.THERMACUT.COM
TEL.: 1-603-542-6715
CUSTOMERSERVICE@THERMACUT.COM

THERMACUT®, THE CUTTING COMPANY®, FHT-EX®, EX-TRAFIRE®, EX-TRACK®, EX-TRABEAM® AND EX-TRAFLEAME® ARE REGISTERED TRADEMARKS OF THERMACUT, K.S. AND MAY BE REGISTERED IN CZECH REPUBLIC AND/OR OTHER COUNTRIES. ALL OTHER TRADEMARKS ARE PROPERTIES OF THEIR RESPECTIVE OWNERS. THERMACUT IS NO WAY AFFILIATED WITH Precitec®. MOST THERMACUT PARTS ARE MADE FOR OR BY AN IBG COMPANY.

VALID FROM JANUARY 2021 • PREVIOUS VERSION IS NO LONGER VALID. • © COPYRIGHT 2021 BY THERMACUT® CZECH REPUBLIC. ALL RIGHTS RESERVED.

THERMACUT® REPLACEMENT PARTS SUITABLE FOR Precitec® PROTECTION WINDOWS SUITABLE FOR Precitec®

| Part No. | Ref. No. | Description | Std. Pkg. |
|----------|-----------------|--|-----------|
| HG17.511 | HG17.511 | Protection Window D50.00mm × ET = 2.0mm suitable for Precitec® | 1pc |
| HG17.514 | HG17.514 | Protection Window D25.40mm × ET = 4.0mm suitable for Precitec® | 1pc |
| HG17.524 | P0595-56801 | Protection Window D37.00mm × ET = 7.0mm suitable for Precitec® | 1pc |
| HG17.525 | HG17.525 | Protection Window D21.50mm × ET = 2.0mm suitable for Precitec® | 1pc |
| HG17.526 | 766719 | Protection Window D30.00mm × ET = 5.0mm suitable for TRUMPF® | 1pc |
| HG17.527 | HG17.527 | Protection Window D30.00mm × ET = 1.50mm YW30 suitable for Precitec® | 1pc |
| HG17.512 | P0589-360-00001 | Protection Window D22.35mm × ET = 4.0mm suitable for Precitec® | 1pc |

ACCESSORIES SUITABLE FOR Precitec®

| Part No. | Ref. No. | Description | Std. Pkg. |
|----------|----------|---|-----------|
| HG10.174 | HG10.174 | Polish for laser optics, 100ml | 1pc |
| HG10.173 | HG10.173 | Lens cleaning paper from TIFFEN®, sheet size 70 × 115mm | 50pcs |

Last update of this page: 07/04/2017. See Revision history for details.

THERMACUT®
THE CUTTING COMPANY™

WWW.THERMACUT.CZ
TEL.: +420 556 423 418
SALES@THERMACUT.CZ

WWW.THERMACUT.DE
TEL.: +49 (0) 27 39 40 33 0
INFO@THERMACUT.DE

WWW.THERMACUT.COM
TEL.: 1-603-542-6715
CUSTOMERSERVICE@THERMACUT.COM

THERMACUT®, THE CUTTING COMPANY®, FHT-EX®, EX-TRAFIRE®, EX-TRACK®, EX-TRABEAM® AND EX-TRAFLEAME® ARE REGISTERED TRADEMARKS OF THERMACUT, K.S. AND MAY BE REGISTERED IN CZECH REPUBLIC AND/OR OTHER COUNTRIES. ALL OTHER TRADEMARKS ARE PROPERTIES OF THEIR RESPECTIVE OWNERS. THERMACUT IS NO WAY AFFILIATED WITH Precitec®, TRUMPF® AND THE TIFFEN COMPANY. MOST THERMACUT PARTS ARE MADE FOR OR BY AN IBG COMPANY.
VALID FROM JANUARY 2021 • PREVIOUS VERSION IS NO LONGER VALID. • © COPYRIGHT 2021 BY THERMACUT® CZECH REPUBLIC. ALL RIGHTS RESERVED.

THERMACUT® REPLACEMENT PARTS SUITABLE FOR PRIMA POWER®

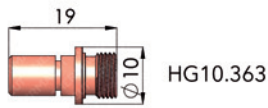

HG10.363

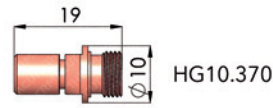

HG10.370

Standard copper nozzles

| Part No. | Ref. No. | Description | Std. Pkg. | Part No. | Ref. No. | Description | Std. Pkg. |
|----------|-------------|---------------------------|-----------|----------|----------|--------------|-----------|
| HG10.363 | 485.73.114C | Nozzle 1.5mm (485.73.321) | 10pcs | HG10.450 | HG10.450 | Nozzle 2.0mm | 10pcs |
| HG10.370 | 485.73.114E | Nozzle 2.0mm (485.73.322) | 10pcs | HG10.451 | HG10.451 | Nozzle 2.5mm | 10pcs |
| HG10.371 | 485.73.114F | Nozzle 2.5mm (485.73.323) | 10pcs | | | | |

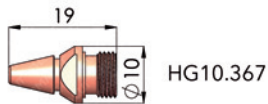

HG10.367

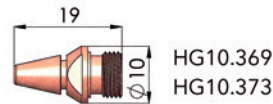

HG10.369
HG10.373

| Part No. | Ref. No. | Description | Std. Pkg. | Part No. | Ref. No. | Description | Std. Pkg. |
|----------|-------------|---------------------------|-----------|----------|------------|--------------|-----------|
| HG10.367 | 485.73.115A | Nozzle 1.5mm (485.73.331) | 10pcs | HG11.367 | 485.73.451 | Nozzle 1.5mm | 10pcs |
| HG10.369 | 485.73.115C | Nozzle 2.0mm (485.73.333) | 10pcs | HG11.369 | 485.73.452 | Nozzle 2.0mm | 10pcs |
| HG10.373 | 485.73.115F | Nozzle 2.5mm | 10pcs | HG11.373 | 485.73.453 | Nozzle 2.5mm | 10pcs |

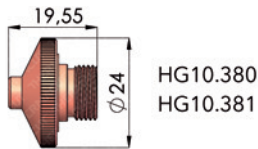

HG10.380
HG10.381

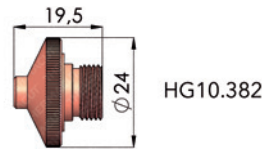

HG10.382

| Part No. | Ref. No. | Description | Std. Pkg. | Part No. | Ref. No. | Description | Std. Pkg. |
|----------|------------|--------------|-----------|----------|------------|--------------|-----------|
| HG10.380 | LW6.1E.111 | Nozzle 1.5mm | 10pcs | HG10.454 | LW6.1G.600 | Nozzle 1.5mm | 10pcs |
| HG10.381 | LW6.1E.112 | Nozzle 2.0mm | 10pcs | HG10.455 | LW6.1G.601 | Nozzle 2.0mm | 10pcs |
| HG10.382 | LW6.1E.113 | Nozzle 2.5mm | 10pcs | HG10.456 | LW6.1G.602 | Nozzle 2.5mm | 10pcs |
| HG10.383 | LW6.1E.114 | Nozzle 3.0mm | 10pcs | HG10.457 | LW6.1G.603 | Nozzle 3.0mm | 10pcs |

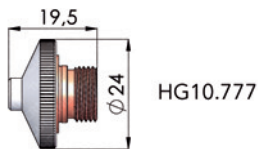

HG10.777

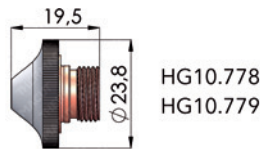

HG10.778
HG10.779

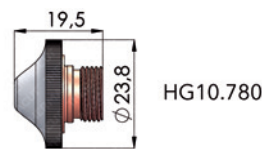

HG10.780

| Part No. | Ref. No. | Description | Std. Pkg. | Part No. | Ref. No. | Description | Std. Pkg. |
|----------|------------|-----------------|-----------|----------|------------|------------------|-----------|
| HG10.777 | LW6.1G.650 | Nozzle 3.0mm CP | 10pcs | HG10.781 | HG10.781 | Nozzle 1.75mm CP | 10pcs |
| HG10.778 | LW6.1G.608 | Nozzle 3.0mm CP | 10pcs | HG10.782 | LW6.1G.605 | Nozzle 2.0mm CP | 10pcs |
| HG10.779 | LW6.1G.609 | Nozzle 3.5mm CP | 10pcs | HG10.783 | LW6.1G.606 | Nozzle 2.5mm CP | 10pcs |
| HG10.780 | LW6.1G.604 | Nozzle 1.5mm CP | 10pcs | HG10.784 | LW6.1G.607 | Nozzle 3.0mm CP | 10pcs |

| Part No. | Ref. No. | Description | Std. Pkg. | Part No. | Ref. No. | Description | Std. Pkg. |
|------------|--------------|--------------|-----------|------------|--------------|--------------|-----------|
| HG11.366/C | HG11.366CP | Nozzle 1.2mm | 10pcs | HG11.369/C | 485.73.452CP | Nozzle 2.0mm | 10pcs |
| HG11.367/C | 485.73.451CP | Nozzle 1.5mm | 10pcs | HG11.373/C | 485.73.453CP | Nozzle 2.5mm | 10pcs |

Last update of this page: 02/07/2018. See Revision history for details.

THERMACUT®
THE CUTTING COMPANY®

WWW.THERMACUT.CZ
TEL.: +420 556 423 418
SALES@THERMACUT.CZ

WWW.THERMACUT.DE
TEL.: +49 (0) 27 39 40 33 0
INFO@THERMACUT.DE

WWW.THERMACUT.COM
TEL.: 1-603-542-6715
CUSTOMERSERVICE@THERMACUT.COM

THERMACUT®, THE CUTTING COMPANY®, FHT-EX®, EX-TRAFIRE®, EX-TRACK®, EX-TRABEAM® AND EX-TRAFLEAME® ARE REGISTERED TRADEMARKS OF THERMACUT, K.S. AND MAY BE REGISTERED IN CZECH REPUBLIC AND/OR OTHER COUNTRIES. ALL OTHER TRADEMARKS ARE PROPERTIES OF THEIR RESPECTIVE OWNERS. THERMACUT IS NO WAY AFFILIATED WITH PRIMA POWER®. MOST THERMACUT PARTS ARE MADE FOR OR BY AN IBG COMPANY.
VALID FROM JANUARY 2021 • PREVIOUS VERSION IS NO LONGER VALID. • © COPYRIGHT 2021 BY THERMACUT® CZECH REPUBLIC. ALL RIGHTS RESERVED.

THERMACUT® REPLACEMENT PARTS SUITABLE FOR PRIMA POWER®

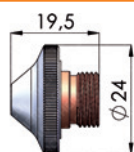

HG11.381/C

Domino copper nozzels with chromium plating

| Part No. | Ref. No. | Description | Std. Pkg. | Part No. | Ref. No. | Description | Std. Pkg. |
|------------|----------------|-------------------------|-----------|------------|----------------|-------------------------|-----------|
| HG11.380/C | 1059.70000.008 | Double Nozzle 1.2mm HCP | 10pcs | HG11.382/C | 1059.70000.005 | Double Nozzle 2.0mm HCP | 10pcs |
| HG11.381/C | 1059.70000.004 | Double Nozzle 1.5mm HCP | 10pcs | HG11.383/C | 1059.70000.006 | Double Nozzle 2.5mm HCP | 10pcs |



PRODUCT BROCHURE WITH DETAILS AT
WWW.THERMACUT.COM

VIDEO AVAILABLE AT YOUTUBE CHANNEL ▶

LENSES SUITABLE FOR PRIMA POWER®

| Part No. | Ref. No. | Description | Std. Pkg. | Part No. | Ref. No. | Description | Std. Pkg. |
|------------|------------|--|-----------|-------------|-------------|--|-----------|
| HG10.733/H | HG10.733/H | 5.00" ZnSe Meniscus lens High pressure lens (42bar), 38.1mm Effective focal length: 127.0mm Edge thickness: 9.0mm AR/AR for 10.6µm (absorption <0.20%) | 1pc | HG10.733/HU | HG10.733/HU | 5.00" ZnSe Men. lens - ULTRA LOW High pressure lens (42bar), 38.1mm Effective focal length: 127.0mm Edge thickness: 9.0mm AR/AR for 10.6µm (absorption <0.13%) | 1pc |
| HG10.734/H | HG10.734/H | 7.50" ZnSe Meniscus lens High pressure lens (42bar), 38.1mm Effective focal length: 190.5mm Edge thickness: 9.0mm AR/AR for 10.6µm (absorption <0.20%) | 1pc | HG10.734/HU | HG10.734/HU | 7.50" ZnSe Men. lens - ULTRA LOW High pressure lens (42bar), 38.1mm Effective focal length: 190.5mm Edge thickness: 9.0mm AR/AR for 10.6µm (absorption <0.13%) | 1pc |
| HG10.620/H | HG10.620/H | 5.00" ZnSe Meniscus lens High pressure lens (28bar), 50.8mm Effective focal length: 127.0mm Edge thickness: 9.7mm AR/AR for 10.6µm (absorption <0.20%) | 1pc | HG10.620/HU | HG10.620/HU | 5.00" ZnSe Men. lens - ULTRA LOW High pressure lens (28bar), 50.8mm Effective focal length: 127.0mm Edge thickness: 9.7mm AR/AR for 10.6µm (absorption <0.13%) | 1pc |
| HG10.621/H | HG10.621/H | 7.50" ZnSe Meniscus lens High pressure lens (28bar), 50.8mm Effective focal length: 190.5mm Edge thickness: 9.7mm AR/AR for 10.6µm (absorption <0.20%) | 1pc | HG10.621/HU | HG10.621/HU | 7.50" ZnSe Men. lens - ULTRA LOW High pressure lens (28bar), 50.8mm Effective focal length: 190.5mm Edge thickness: 9.7mm AR/AR for 10.6µm (absorption <0.13%) | 1pc |

PROTECTION WINDOWS SUITABLE FOR PRIMA POWER®

| Part No. | Ref. No. | Description | Std. Pkg. |
|----------|----------|---|-----------|
| HG17.520 | HG17.520 | Protection Window D38.00mm × ET = 2.0mm | 1pc |

ACCESSORIES SUITABLE FOR PRIMA POWER®

| Part No. | Ref. No. | Description | Std. Pkg. |
|----------|----------|---|-----------|
| HG10.174 | HG10.174 | Polish for laser optics, 100ml | 1pc |
| HG10.173 | HG10.173 | Lens cleaning paper from TIFFEN®, sheet size 70 × 115mm | 50pcs |

Last update of this page: 30/05/2018. See Revision history for details.

THERMACUT®
THE CUTTING COMPANY™

WWW.THERMACUT.CZ
TEL.: +420 556 423 418
SALES@THERMACUT.CZ

WWW.THERMACUT.DE
TEL.: +49 (0) 27 39 40 33 0
INFO@THERMACUT.DE

WWW.THERMACUT.COM
TEL.: 1-603-542-6715
CUSTOMERSERVICE@THERMACUT.COM

THERMACUT®, THE CUTTING COMPANY®, FHT-EX®, EX-TRAFIRE®, EX-TRACK®, EX-TRABEAM® AND EX-TRAFLEAME® ARE REGISTERED TRADEMARKS OF THERMACUT, K.S. AND MAY BE REGISTERED IN CZECH REPUBLIC AND/OR OTHER COUNTRIES. ALL OTHER TRADEMARKS ARE PROPERTIES OF THEIR RESPECTIVE OWNERS. THERMACUT IS NO WAY AFFILIATED WITH PRIMA POWER® AND THE TIFFEN COMPANY. MOST THERMACUT PARTS ARE MADE FOR OR BY AN IBG COMPANY.
VALID FROM JANUARY 2021 • PREVIOUS VERSION IS NO LONGER VALID. • © COPYRIGHT 2021 BY THERMACUT® CZECH REPUBLIC. ALL RIGHTS RESERVED.

THERMACUT® REPLACEMENT PARTS SUITABLE FOR TRUMPF®

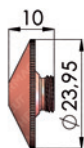

HG10.150–HG10.153
HG10.148
HG10.159



HG10.150/C–HG10.152/C
HG10.148/C

Standard copper nozzles / Standard copper nozzles with hard chromium plating

| Part No. | Ref. No. | Description | Std. Pkg. | Part No. | Ref. No. | Description | Std. Pkg. |
|------------|----------|-------------------------------------|-----------|------------|----------|----------------------|-----------|
| HG10.150 | 0124561 | Nozzle ECE 0.8mm | 10pcs | HG10.154 | 0237501 | Nozzle ECE 1.7mm | 10pcs |
| HG10.150/C | 0352280 | Nozzle ECE 0.8mm HCP | 10pcs | HG10.154/C | 0352284 | Nozzle ECE 1.7mm HCP | 10pcs |
| HG10.151 | 0124562 | Nozzle ECE 1.0mm | 10pcs | HG10.155 | 1253211 | Nozzle ECE 2.0mm | 10pcs |
| HG10.151/C | 0352281 | Nozzle ECE 1.0mm HCP | 10pcs | HG10.155/C | 1253212 | Nozzle ECE 2.0mm HCP | 10pcs |
| HG10.148 | 0966809 | Nozzle ECE 1.2mm | 10pcs | HG10.158 | 0126933 | Nozzle ECE 2.3mm | 10pcs |
| HG10.148/C | 0352282 | Nozzle ECE 1.2mm HCP | 10pcs | HG10.158/C | 0352285 | Nozzle ECE 2.3mm HCP | 10pcs |
| HG10.152 | 0237497 | Nozzle ECE 1.4mm with step | 10pcs | HG10.156 | HG10.156 | Nozzle ECE 2.5mm | 10pcs |
| HG10.152/C | 0352283 | Nozzle ECE 1.4mm HCP | 10pcs | HG10.149 | 0942742 | Nozzle ECE 2.7mm | 10pcs |
| HG10.159 | 237497-S | Nozzle ECE 1.4mm with Straith Taper | 10pcs | HG10.149/C | 0352286 | Nozzle ECE 2.7mm HCP | 10pcs |
| HG10.153 | 237500 | Nozzle ECE 1.5mm | 10pcs | HG10.157 | 0237504 | Nozzle ECE 3.0mm | 10pcs |

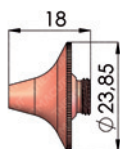

HG10.130–HG10.133

| Part No. | Ref. No. | Description | Std. Pkg. | Part No. | Ref. No. | Description | Std. Pkg. |
|----------|----------|--------------|-----------|----------|----------|--------------|-----------|
| HG10.130 | 1277773 | Nozzle 0.8mm | 10pcs | HG10.134 | 1277779 | Nozzle 1.7mm | 10pcs |
| HG10.131 | 1277771 | Nozzle 1.0mm | 10pcs | HG10.135 | 1277780 | Nozzle 2.0mm | 10pcs |
| HG10.132 | 1277774 | Nozzle 1.2mm | 10pcs | HG10.136 | 1277781 | Nozzle 2.3mm | 10pcs |
| HG10.133 | 1277776 | Nozzle 1.4mm | 10pcs | HG10.137 | 1277782 | Nozzle 2.7mm | 10pcs |

Last update of this page: 02/07/2018. See Revision history for details.

THERMACUT®
THE CUTTING COMPANY™

WWW.THERMACUT.CZ
TEL.: +420 556 423 418
SALES@THERMACUT.CZ

WWW.THERMACUT.DE
TEL.: +49 (0) 27 39 40 33 0
INFO@THERMACUT.DE

WWW.THERMACUT.COM
TEL.: 1-603-542-6715
CUSTOMERSERVICE@THERMACUT.COM

THERMACUT®, THE CUTTING COMPANY®, FHT-EX®, EX-TRAFIRE®, EX-TRACK®, EX-TRABEAM® AND EX-TRAFLEAME® ARE REGISTERED TRADEMARKS OF THERMACUT, K.S. AND MAY BE REGISTERED IN CZECH REPUBLIC AND/OR OTHER COUNTRIES. ALL OTHER TRADEMARKS ARE PROPERTIES OF THEIR RESPECTIVE OWNERS. THERMACUT IS NO WAY AFFILIATED WITH TRUMPF®. MOST THERMACUT PARTS ARE MADE FOR OR BY AN IBG COMPANY.
VALID FROM JANUARY 2021 • PREVIOUS VERSION IS NO LONGER VALID. • © COPYRIGHT 2021 BY THERMACUT® CZECH REPUBLIC. ALL RIGHTS RESERVED.

THERMACUT® REPLACEMENT PARTS SUITABLE FOR TRUMPF®

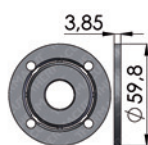

HG10.163



HG10.107



HG10.109

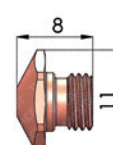

HG10.040



HG10.162

| Part No. | Ref. No. | Description | Std. Pkg. |
|------------|----------|-------------------------------------|-----------|
| HG10.163 | 234485 | Break Away Bar | 1pc |
| HG10.107 | 0258809 | Ceramic Nozzle Holder (Lasermatic®) | 1pc |
| HG10.109 | 0260432 | Ceramic Nozzle Holder DIAS III | 1pc |
| HG10.080 | 1755673 | Nozzle Holder M12 | 1pc |
| HG10.040 | 1589610 | Nozzle - 2.0mm Blow Off | 1pc |
| HG10.162 | 256153 | PTFE Cover DIAS III White | 1pc |
| HG10.162/1 | 0955826 | PTFE Cover DIAS III Black | 1pc |

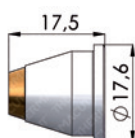

HG10.031

| Part No. | Ref. No. | Description | Std. Pkg. |
|----------|----------|-----------------------|-----------|
| HG10.031 | 0936678 | Ceramic Nozzle Holder | 1pc |

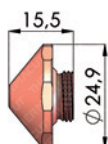

HG10.060-HG10.067

| Part No. | Ref. No. | Description | Std. Pkg. | Part No. | Ref. No. | Description | Std. Pkg. |
|----------|----------|------------------|-----------|----------|----------|------------------|-----------|
| HG10.060 | 1324858 | Nozzle EAA 0.8mm | 10pcs | HG10.070 | 1373324 | Nozzle EAB 0.8mm | 10pcs |
| HG10.061 | 1324860 | Nozzle EAA 1.0mm | 10pcs | HG10.071 | 1373325 | Nozzle EAB 1.0mm | 10pcs |
| HG10.062 | 1324861 | Nozzle EAA 1.2mm | 10pcs | HG10.072 | 1373326 | Nozzle EAB 1.2mm | 10pcs |
| HG10.063 | 1324863 | Nozzle EAA 1.4mm | 10pcs | HG10.073 | 1373327 | Nozzle EAB 1.4mm | 10pcs |
| HG10.064 | 1324864 | Nozzle EAA 1.7mm | 10pcs | HG10.074 | 1373328 | Nozzle EAB 1.7mm | 10pcs |
| HG10.065 | 1324865 | Nozzle EAA 2.0mm | 10pcs | HG10.075 | 1373329 | Nozzle EAB 2.0mm | 10pcs |
| HG10.066 | 1324866 | Nozzle EAA 2.3mm | 10pcs | HG10.076 | 1373330 | Nozzle EAB 2.3mm | 10pcs |
| HG10.067 | 1324867 | Nozzle EAA 2.7mm | 10pcs | HG10.077 | 1373331 | Nozzle EAB 2.7mm | 10pcs |

PolyTetraFluoroEthylene is a fluorocarbon-based polymer and is commonly abbreviated PTFE. The Teflon® brand of PTFE is manufactured only by DuPont® and is not sold by Thermacut. Thermacut purchases other brands of PTFE from various high quality manufacturers.

Last update of this page: 28/02/2019. See Revision history for details.

THERMACUT®
THE CUTTING COMPANY™

WWW.THERMACUT.CZ
TEL.: +420 556 423 418
SALES@THERMACUT.CZ

WWW.THERMACUT.DE
TEL.: +49 (0) 27 39 40 33 0
INFO@THERMACUT.DE

WWW.THERMACUT.COM
TEL.: 1-603-542-6715
CUSTOMERSERVICE@THERMACUT.COM

THERMACUT®, THE CUTTING COMPANY®, FHT-EX®, EX-TRAFIRE®, EX-TRACK®, EX-TRABEAM® AND EX-TRAFLEAME® ARE REGISTERED TRADEMARKS OF THERMACUT, K.S. AND MAY BE REGISTERED IN CZECH REPUBLIC AND/OR OTHER COUNTRIES. ALL OTHER TRADEMARKS ARE PROPERTIES OF THEIR RESPECTIVE OWNERS. THERMACUT IS NO WAY AFFILIATED WITH TRUMPF®. MOST THERMACUT PARTS ARE MADE FOR OR BY AN IBG COMPANY.

VALID FROM JANUARY 2021 • PREVIOUS VERSION IS NO LONGER VALID. • © COPYRIGHT 2021 BY THERMACUT® CZECH REPUBLIC. ALL RIGHTS RESERVED.

THERMACUT® REPLACEMENT PARTS SUITABLE FOR TRUMPF®
PARTS SUITABLE FOR TRUMPF® BRIGHTLINE™ SERIES AND COOLLINE™ SERIES

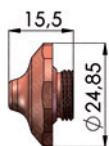

HG10.081–HG10.084

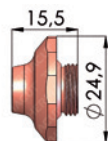

HG10.085

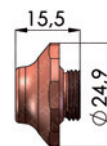

HG10.086

| Part No. | Ref. No. | Description | Std. Pkg. | Part No. | Ref. No. | Description | Std. Pkg. |
|----------|----------|------------------------------|-----------|----------|----------|------------------------------|-----------|
| HG10.081 | 1664569 | BrightLine™ Nozzle EAN 1.7mm | 1pc | HG10.087 | 1809421 | BrightLine™ Nozzle EAQ 7.5mm | 1pc |
| HG10.082 | 1664602 | BrightLine™ Nozzle EAN 2.0mm | 1pc | HG10.088 | 1886199 | BrightLine™ Nozzle EAQ 9.5mm | 1pc |
| HG10.083 | 1664625 | BrightLine™ Nozzle EAN 2.5mm | 1pc | HG10.089 | 1774018 | CoolLine™ Nozzle EFL 1.4mm | 1pc |
| HG10.084 | 1835747 | BrightLine™ Nozzle EAK 4.0mm | 1pc | HG10.090 | 1774020 | CoolLine™ Nozzle EFL 2.0mm | 1pc |
| HG10.085 | 1633046 | BrightLine™ Nozzle EAC 5.3mm | 1pc | HG10.091 | 1774092 | CoolLine™ Nozzle EFL 2.3mm | 1pc |
| HG10.086 | 1809091 | BrightLine™ Nozzle EAQ 6.0mm | 1pc | | | | |

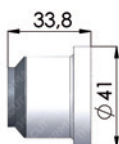

HG10.045

| Part No. | Ref. No. | Description | Std. Pkg. |
|----------|----------|-----------------------------|-----------|
| HG10.045 | 1906032 | Ceramic Coolline/Brightline | 1pc |

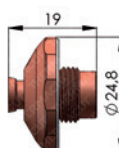

HG10.092–HG10.095

| Part No. | Ref. No. | Description | Std. Pkg. |
|----------|----------|---------------------------|-----------|
| HG10.092 | 1879940 | CoolLine™ Nozzle EGL D1.4 | 10pcs |
| HG10.093 | 1879951 | CoolLine™ Nozzle EGL D1.7 | 10pcs |
| HG10.094 | 1879952 | CoolLine™ Nozzle EGL D2.0 | 10pcs |
| HG10.095 | 1879953 | CoolLine™ Nozzle EGL D2.3 | 10pcs |

Last update of this page: 02/07/2018. See Revision history for details.

THERMACUT®
THE CUTTING COMPANY®

WWW.THERMACUT.CZ
TEL.: +420 556 423 418
SALES@THERMACUT.CZ

WWW.THERMACUT.DE
TEL.: +49 (0) 27 39 40 33 0
INFO@THERMACUT.DE

WWW.THERMACUT.COM
TEL.: 1-603-542-6715
CUSTOMERSERVICE@THERMACUT.COM

THERMACUT®, THE CUTTING COMPANY®, FHT-EX®, EX-TRAFIRE®, EX-TRACK®, EX-TRABEAM® AND EX-TRAFLEAME® ARE REGISTERED TRADEMARKS OF THERMACUT, K.S. AND MAY BE REGISTERED IN CZECH REPUBLIC AND/OR OTHER COUNTRIES. ALL OTHER TRADEMARKS ARE PROPERTIES OF THEIR RESPECTIVE OWNERS. THERMACUT IS NO WAY AFFILIATED WITH TRUMPF®. MOST THERMACUT PARTS ARE MADE FOR OR BY AN IBG COMPANY.
 VALID FROM JANUARY 2021 • PREVIOUS VERSION IS NO LONGER VALID. • © COPYRIGHT 2021 BY THERMACUT® CZECH REPUBLIC. ALL RIGHTS RESERVED.

THERMACUT® REPLACEMENT PARTS SUITABLE FOR TRUMPF® PARTS SUITABLE FOR TRUMPF® PERFORMANCE™ SERIES

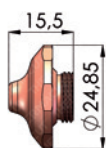

HG10.096–HG10.098

| Part No. | Ref. No. | Description | Std. Pkg. | Part No. | Ref. No. | Description | Std. Pkg. |
|----------|----------|------------------|-----------|----------|----------|-------------------|-----------|
| HG10.096 | 2059462 | Nozzle EAU 2.5mm | 10pcs | HG10.041 | 2253595 | Nozzle EAU 10.0mm | 10pcs |
| HG10.097 | 2060001 | Nozzle EAU 3.0mm | 10pcs | | | | |
| HG10.098 | 2060004 | Nozzle EAU 4.0mm | 10pcs | | | | |
| HG10.099 | 2060025 | Nozzle EAU 6.0mm | 10pcs | | | | |

THERMACUT® REPLACEMENT PARTS SUITABLE FOR TRUMPF®

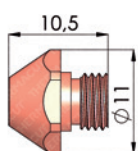

HG10.036
HG10.010
HG10.012
HG10.028

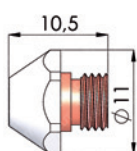

HG10.036/C
HG10.010/C
HG10.025/C
HG10.012/C
HG10.028/C

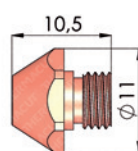

HG10.025

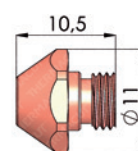

HG10.037
HG10.011

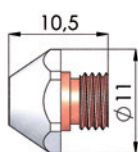

HG10.011/C

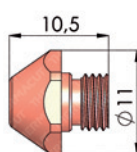

HG10.038

| Part No. | Ref. No. | Description | Std. Pkg. | Part No. | Ref. No. | Description | Std. Pkg. |
|------------|------------|-------------------------|-----------|----------|----------|-----------------|-----------|
| HG10.036 | 1354230 | Nozzle EBD 0.8mm | 10pcs | HG16.600 | HG16.600 | Nozzle 0.8mm | 10pcs |
| HG10.036/C | 1354230CP | Nozzle EBD 0.8mm HCP | 10pcs | HG10.013 | 226939 | Nozzle 1.0mm | 10pcs |
| HG10.010 | 0212334 | Nozzle EBD 1.0mm | 10pcs | HG10.026 | HG10.026 | Nozzle 1.0mm HD | 10pcs |
| HG10.010/C | 0212334CP | Nozzle EBD 1.0mm HCP | 10pcs | HG10.014 | 226940 | Nozzle 1.4mm HD | 10pcs |
| HG10.025 | HG10.025 | Nozzle 1.0mm HD | 10pcs | HG10.015 | 227144 | Nozzle 1.7mm HD | 10pcs |
| HG10.025/C | HG10.025CP | Nozzle 1.0mm HD HCP | 10pcs | HG10.029 | HG10.029 | Nozzle 2.3mm HD | 10pcs |
| HG10.037 | 1479581 | Nozzle EBD 1.2mm | 10pcs | HG10.033 | HG10.033 | Nozzle 2.0mm HD | 10pcs |
| HG10.011 | 0216199 | Nozzle EBD 1.4mm HD | 10pcs | | | | |
| HG10.011/C | 0216199CP | Nozzle EBD 1.4mm HD HCP | 10pcs | | | | |
| HG10.012 | 0225213 | Nozzle EBD 1.7mm HD | 10pcs | | | | |
| HG10.012/C | 0225213CP | Nozzle EBD 1.7mm HD HCP | 10pcs | | | | |
| HG10.038 | 1487009 | Nozzle EBD 2.0mm | 10pcs | | | | |
| HG10.028 | 0126156 | Nozzle EBD 2.3mm HD | 10pcs | | | | |
| HG10.028/C | 0126156CP | Nozzle EBD 2.3mm HD HCP | 10pcs | | | | |

Last update of this page: 02/07/2018. See Revision history for details.

THERMACUT®
THE CUTTING COMPANY®

WWW.THERMACUT.CZ
TEL.: +420 556 423 418
SALES@THERMACUT.CZ

WWW.THERMACUT.DE
TEL.: +49 (0) 27 39 40 33 0
INFO@THERMACUT.DE

WWW.THERMACUT.COM
TEL.: 1-603-542-6715
CUSTOMERSERVICE@THERMACUT.COM

THERMACUT®, THE CUTTING COMPANY®, FHT-EX®, EX-TRAFIRE®, EX-TRACK®, EX-TRABEAM® AND EX-TRAFLEAME® ARE REGISTERED TRADEMARKS OF THERMACUT, K.S. AND MAY BE REGISTERED IN CZECH REPUBLIC AND/OR OTHER COUNTRIES. ALL OTHER TRADEMARKS ARE PROPERTIES OF THEIR RESPECTIVE OWNERS. THERMACUT IS NO WAY AFFILIATED WITH TRUMPF®. MOST THERMACUT PARTS ARE MADE FOR OR BY AN IBG COMPANY.

VALID FROM JANUARY 2021 • PREVIOUS VERSION IS NO LONGER VALID. • © COPYRIGHT 2021 BY THERMACUT® CZECH REPUBLIC. ALL RIGHTS RESERVED.

THERMACUT® REPLACEMENT PARTS SUITABLE FOR TRUMPF®

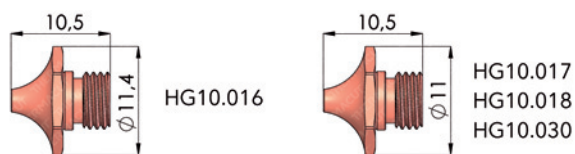

| Part No. | Ref. No. | Description | Std. Pkg. | Part No. | Ref. No. | Description | Std. Pkg. |
|----------|----------|------------------------|-----------|----------|----------|-----------------|-----------|
| HG10.016 | HG10.016 | Nozzle 1.0mm | 10pcs | HG10.225 | 0135320 | Nozzle 1.0mm RE | 10pcs |
| HG10.017 | HG10.017 | Nozzle 1.4mm HD | 10pcs | HG10.226 | HG10.226 | Nozzle 1.2mm RE | 10pcs |
| HG10.018 | HG10.018 | Nozzle 1.7mm HD | 10pcs | HG10.220 | 0135318 | Nozzle 1.4mm RE | 10pcs |
| HG10.030 | HG10.030 | Nozzle 2.3mm HD | 10pcs | HG10.221 | 0126157 | Nozzle 1.7mm RE | 10pcs |
| HG10.008 | HG10.008 | Teach Nozzle 0.25mm RE | 1pc | | | | |



| Part No. | Ref. No. | Description | Std. Pkg. | Part No. | Ref. No. | Description | Std. Pkg. |
|------------|-----------|-------------------------|-----------|------------|-----------|-------------------------|-----------|
| HG10.020 | 0913799 | Nozzle EBG 0.8mm HD | 10pcs | HG10.022/C | 0913801CP | Nozzle EBG 1.4mm HD HCP | 10pcs |
| HG10.020/C | 0913799CP | Nozzle EBG 0.8mm HD HCP | 10pcs | HG10.023 | 0937988 | Nozzle EBG 1.7mm HD | 10pcs |
| HG10.021 | 0913800 | Nozzle EBG 1.0mm HD | 10pcs | HG10.023/C | 0937988CP | Nozzle EBG 1.7mm HD HCP | 10pcs |
| HG10.021/C | 0913800CP | Nozzle EBG 1.0mm HD HCP | 10pcs | HG10.024 | 0937989 | Nozzle EBG 2.3mm HD | 10pcs |
| HG10.039 | 1487034 | Nozzle EBG 1.2mm | 10pcs | HG10.024/C | 0937989CP | Nozzle 2.3mm HD HCP | 10pcs |
| HG10.022 | 0913801 | Nozzle EBG 1.4mm HD | 10pcs | HG10.027 | 1487036 | Nozzle EBG 2.0mm | 10pcs |

Last update of this page: 13/09/2017. See Revision history for details.

THERMACUT®
THE CUTTING COMPANY®

WWW.THERMACUT.CZ
TEL.: +420 556 423 418
SALES@THERMACUT.CZ

WWW.THERMACUT.DE
TEL.: +49 (0) 27 39 40 33 0
INFO@THERMACUT.DE

WWW.THERMACUT.COM
TEL.: 1-603-542-6715
CUSTOMERSERVICE@THERMACUT.COM

THERMACUT®, THE CUTTING COMPANY®, FHT-EX®, EX-TRAFIRE®, EX-TRACK®, EX-TRABEAM® AND EX-TRAFLEAME® ARE REGISTERED TRADEMARKS OF THERMACUT, K.S. AND MAY BE REGISTERED IN CZECH REPUBLIC AND/OR OTHER COUNTRIES. ALL OTHER TRADEMARKS ARE PROPERTIES OF THEIR RESPECTIVE OWNERS. THERMACUT IS NO WAY AFFILIATED WITH TRUMPF®. MOST THERMACUT PARTS ARE MADE FOR OR BY AN IBG COMPANY.
VALID FROM JANUARY 2021 • PREVIOUS VERSION IS NO LONGER VALID. • © COPYRIGHT 2021 BY THERMACUT® CZECH REPUBLIC. ALL RIGHTS RESERVED.

THERMACUT® REPLACEMENT PARTS SUITABLE FOR TRUMPF®

LENSES SUITABLE FOR TRUMPF®



| Part No. | Ref. No. | Description | Std. Pkg. | Part No. | Ref. No. | Description | Std. Pkg. |
|------------|----------|---|-----------|-------------|----------|---|-----------|
| HG10.166/H | 346104 | 3.75" ZnSe Meniscus lens High pressure lens (29bar), 38.1mm Effective focal length: 95.3mm Edge thickness: 7.4mm AR/AR for 10.6µm (absorption <0.20%) | 1pc | HG10.167/HU | 88114 | 5.00" ZnSe Meniscus lens - ULTRA LOW High pressure lens (29bar), 38.1mm Effective focal length: 127.0mm Edge thickness: 7.4mm AR/AR for 10.6µm (absorption <0.13%) | 1pc |
| HG10.167/H | 88114 | 5.00" ZnSe Meniscus lens High pressure lens (29bar), 38.1mm Effective focal length: 127.0mm Edge thickness: 7.4mm AR/AR for 10.6µm (absorption <0.20%) | 1pc | HG10.168/HU | 97517 | 7.50" ZnSe Meniscus lens - ULTRA LOW High pressure lens (29bar), 38.1mm Effective focal length: 190.5mm Edge thickness: 7.4mm AR/AR for 10.6µm (absorption <0.13%) | 1pc |
| HG10.168/H | 97517 | 7.50" ZnSe Meniscus lens High pressure lens (29bar), 38.1mm Effective focal length: 190.5mm Edge thickness: 7.4mm AR/AR for 10.6µm (absorption <0.20%) | 1pc | HG10.169/HU | 141972 | 9.00" ZnSe Meniscus lens - ULTRA LOW High pressure lens (29bar), 38.1mm Effective focal length: 225.0mm Edge thickness: 7.4mm AR/AR for 10.6µm (absorption <0.13%) | |
| HG10.169/H | 141972 | 9.00" ZnSe Meniscus lens High pressure lens (29bar), 38.1mm Effective focal length: 225.0mm Edge thickness: 7.4mm AR/AR for 10.6µm (absorption <0.20%) | 1pc | HG10.179/HU | 350163 | 10.00" ZnSe Meniscus lens - ULTRA LOW High pressure lens (29bar), 38.1mm Effective focal length: 254.0mm Edge thickness: 7.4mm AR/AR for 10.6µm (absorption <0.13%) | |
| HG10.179/H | 350163 | 10.00" ZnSe Meniscus lens High pressure lens (29bar), 38.1mm Effective focal length: 254.0mm Edge thickness: 7.4mm AR/AR for 10.6µm (absorption <0.20%) | 1pc | | | | |

OPTICS, SERVICE ITEMS AND SPARE PARTS SUITABLE FOR TRUMPF®

PROTECTION WINDOWS SUITABLE FOR TRUMPF®

| Part No. | Ref. No. | Description | Std. Pkg. |
|----------|----------|--|-----------|
| HG17.513 | 1614767 | Protection Window D34.00mm × ET = 5.0mm | 1pc |
| HG17.515 | 759720 | Protection Window D55.00mm × ET = 1.50mm | 1pc |
| HG17.526 | 766719 | Protection Window D30.00mm × ET = 5.0mm | 1pc |

Last update of this page: 02/07/2018. See Revision history for details.

THERMACUT®
THE CUTTING COMPANY®

WWW.THERMACUT.CZ
TEL.: +420 556 423 418
SALES@THERMACUT.CZ

WWW.THERMACUT.DE
TEL.: +49 (0) 27 39 40 33 0
INFO@THERMACUT.DE

WWW.THERMACUT.COM
TEL.: 1-603-542-6715
CUSTOMERSERVICE@THERMACUT.COM

THERMACUT®, THE CUTTING COMPANY®, FHT-EX®, EX-TRAFIRE®, EX-TRACK®, EX-TRABEAM® AND EX-TRAFLEAME® ARE REGISTERED TRADEMARKS OF THERMACUT, K.S. AND MAY BE REGISTERED IN CZECH REPUBLIC AND/OR OTHER COUNTRIES. ALL OTHER TRADEMARKS ARE PROPERTIES OF THEIR RESPECTIVE OWNERS. THERMACUT IS NO WAY AFFILIATED WITH TRUMPF® AND THE TIPPEN COMPANY. MOST THERMACUT PARTS ARE MADE FOR OR BY AN IBG COMPANY.
VALID FROM JANUARY 2021 • PREVIOUS VERSION IS NO LONGER VALID. • © COPYRIGHT 2021 BY THERMACUT® CZECH REPUBLIC. ALL RIGHTS RESERVED.

THERMACUT® REPLACEMENT PARTS SUITABLE FOR TRUMPF® OPTICS, SERVICE ITEMS AND SPARE PARTS SUITABLE FOR TRUMPF®

ACCESSORIES SUITABLE FOR TRUMPF®

| Part No. | Ref. No. | Description | Std. Pkg. |
|----------|----------|---|-----------|
| HG10.174 | HG10.174 | Polish for laser optics, 100ml | 1pc |
| HG10.173 | HG10.173 | Lens cleaning paper from TIFFEN®, sheet size 70 × 115mm | 50pcs |
| HG15.136 | HG15.136 | Latex gloves | 100pcs |

BELLOWS SUITABLE FOR TRUMPF® TC L3030™ and L3020™

| Part No. | Ref. No. | Description | Std. Pkg. |
|----------|----------|--|-----------|
| HG17.100 | 921742 | Bellow x-axis | 1pc |
| HG17.101 | 141394 | Bellow y-axis | 1pc |
| HG17.102 | 1667790 | Chest bellow x-axis front (old No. 920715) | 1pc |
| HG17.103 | 1667803 | Chest bellow x-axis rear (old No. 9390015) | 1pc |
| HG17.104 | 1667801 | Chest bellow y-axis right (old No. 920716) | 1pc |
| HG17.105 | 1667805 | Chest bellow y-axis left (old No. 939016) | 1pc |
| HG17.106 | 910354 | Chest bellow z-axis | 1pc |

BELLOWS SUITABLE FOR TRUMPF® TC L4030™

| Part No. | Ref. No. | Description | Std. Pkg. |
|----------|----------|---------------------------|-----------|
| HG17.110 | 921870 | Bellow x-axis | 1pc |
| HG17.111 | 144949 | Bellow y-axis | 1pc |
| HG17.112 | 939017 | Chest bellow x-axis rear | 1pc |
| HG17.113 | 976624 | Chest bellow x-axis front | 1pc |
| HG17.115 | 920719 | Chest bellow y-axis right | 1pc |
| HG17.116 | 938000 | Chest bellow y-axis left | 1pc |
| HG17.106 | 910354 | Chest bellow z-axis | 1pc |

BELLOWS SUITABLE FOR TRUMPF® TC L3050™

| Part No. | Ref. No. | Description | Std. Pkg. |
|----------|----------|--|-----------|
| HG17.122 | 1302020 | Bellow x-axis front and middle left (Altern. No. 981757/1596087) | 1pc |
| HG17.123 | 981710 | Bellow x-axis front and rear right | 1pc |
| HG17.124 | 1307207 | Bellow x-axis front and rear right (Altern. No. 1596086) | 1pc |
| HG17.125 | 1302018 | Bellow x-axis rear left (Altern. No. 981756/1596088) | 1pc |
| HG17.126 | 1226193 | Bellow y-axis right | 1pc |
| HG17.127 | 1302386 | Bellow u-axis front and rear (Altern. No. 981753) | 1pc |
| HG17.128 | 979561 | Bellow z-axis rear | 1pc |
| HG17.119 | 1226192 | Disc bellow y-axis left (Altern. No. 1353514) | 1pc |
| HG17.120 | 1271514 | Chest bellow u/x-axis front and rear (Altern. No. 978079) | 1pc |
| HG17.106 | 910354 | Chest bellow z-axis | 1pc |

Last update of this page: 25/07/2016. See Revision history for details.

THERMACUT®
THE CUTTING COMPANY®

WWW.THERMACUT.CZ
TEL.: +420 556 423 418
SALES@THERMACUT.CZ

WWW.THERMACUT.DE
TEL.: +49 (0) 27 39 40 33 0
INFO@THERMACUT.DE

WWW.THERMACUT.COM
TEL.: 1-603-542-6715
CUSTOMERSERVICE@THERMACUT.COM

THERMACUT®, THE CUTTING COMPANY®, FHT-EX®, EX-TRAFIRE®, EX-TRACK®, EX-TRABEAM® AND EX-TRAFLEAME® ARE REGISTERED TRADEMARKS OF THERMACUT, K.S. AND MAY BE REGISTERED IN CZECH REPUBLIC AND/OR OTHER COUNTRIES. ALL OTHER TRADEMARKS ARE PROPERTIES OF THEIR RESPECTIVE OWNERS. THERMACUT IS NO WAY AFFILIATED WITH TRUMPF®. MOST THERMACUT PARTS ARE MADE FOR OR BY AN IBG COMPANY.

VALID FROM JANUARY 2021 • PREVIOUS VERSION IS NO LONGER VALID. • © COPYRIGHT 2021 BY THERMACUT® CZECH REPUBLIC. ALL RIGHTS RESERVED.

THERMACUT® REPLACEMENT PARTS SUITABLE FOR TRUMPF®
SERVICE ITEMS AND SPARE PARTS SUITABLE FOR TRUMPF®

BELLOWS SUITABLE FOR TRUMPF® TC L4050™

| Part No. | Ref. No. | Description | Std. Pkg. |
|----------|----------|-------------------------------------|-----------|
| HG17.140 | 1222529 | Bellow x-axis front and middle left | 1pc |
| HG17.141 | 1222573 | Bellow x-axis front and rear right | 1pc |
| HG17.142 | 1222571 | Bellow x-axis rear left | 1pc |
| HG17.143 | 1222111 | Bellow y-axis right | 1pc |
| HG17.144 | 1222528 | Bellow u-axis front and rear | 1pc |
| HG17.128 | 979561 | Bellow z-axis rear | 1pc |
| HG17.146 | 1222575 | Disc bellow x-axis left | 1pc |
| HG17.147 | 1222576 | Disc bellow x-axis right | 1pc |
| HG17.148 | 1222110 | Disk bellow y-axis left | 1pc |
| HG17.106 | 910354 | Chest bellow z-axis | 1pc |

BELLOWS SUITABLE FOR TRUMPF® TC L6030™

| Part No. | Ref. No. | Description | Std. Pkg. |
|----------|----------|---------------------------------------|-----------|
| HG17.150 | 921871 | Bellows x-axis on request | 1pc |
| HG17.111 | 144949 | Bellows y-axis | 1pc |
| HG17.151 | 920730 | Chest bellows x-axis rear on request | 1pc |
| HG17.152 | 937999 | Chest bellows x-axis front on request | 1pc |
| HG17.115 | 920719 | Chest bellows y-axis right | 1pc |
| HG17.116 | 938000 | Chest bellows y-axis left | 1pc |
| HG17.106 | 910354 | Chest bellows z-axis | 1pc |

BELLOWS SUITABLE FOR TRUMPF® TC L6050™

| Part No. | Ref. No. | Description | Std. Pkg. |
|----------|----------|---------------------------|-----------|
| HG17.153 | 1251452 | Bellows x-axis right | 1pc |
| HG17.154 | 1251453 | Bellows x-axis left | 1pc |
| HG17.155 | 1251454 | Bellows x-axis left | 1pc |
| HG17.156 | 1251455 | Bellows u-axis | 1pc |
| HG17.143 | 1222111 | Bellows y-axis righth | 1pc |
| HG17.157 | 979561 | Bellows z-axis rear | 1pc |
| HG17.158 | 1353516 | Disk bellows y-axis left | 1pc |
| HG17.159 | 1306473 | Disk bellows x-axis left | 1pc |
| HG17.160 | 1306474 | Disk bellows x-axis right | 1pc |

Last update of this page: 02/09/2016. See Revision history for details.

THERMACUT® REPLACEMENT PARTS SUITABLE FOR TRUMPF®
SERVICE ITEMS AND SPARE PARTS SUITABLE FOR TRUMPF®

BELLOWS SUITABLE FOR TRUMPF® L3030™ (L20™)

| Part No. | Ref. No. | Description | Std. Pkg. |
|----------|-----------------|---------------------------|-----------|
| HG17.161 | 1458867 | Railing cover left | 1pc |
| HG17.162 | 1458866 | Railing cover right | 1pc |
| HG17.163 | 1512607 | Chest bellows z-axis | 1pc |
| HG17.164 | 1496436 | Disk Bellows y-axis left | 1pc |
| HG17.165 | 1496435 | Disk Bellows y-axis right | 1pc |
| HG17.166 | 1458860 | Disk Bellows | 1pc |
| HG17.167 | 1458861/1854032 | Disk Bellows | 1pc |

FILTER ELEMENTS SUITABLE FOR TRUMPF®

| Part No. | Ref. No. | Description | Std. Pkg. |
|----------|------------------|---|-----------|
| HG17.130 | 146152 | Chisso filter CP10 for water circuit 30 × 68 × 248mm | 1pc |
| HG17.131 | 123674 / 377006 | Filter element Air/N2 | 1pc |
| HG17.132 | 123675 / 377005 | Filter element FFP3 | 1pc |
| HG17.133 | 123676 / 377004 | Filter element AKP 04/20S | 1pc |
| HG17.134 | 365781 | Filter MPF 04/10 | 1pc |
| HG17.135 | 365782 | Filter SMPF 04/10 | 1pc |
| HG17.020 | 941996 / 0149023 | Circuit lubricated rotary valve - Vacuum pump - original HYCO® | 1pc |
| HG17.000 | 0345064 | Filter panel suitable for extraction unit 556 × 74 × 1050mm, H13 suitable for TC L3030™, L4050™, L6050™, L4030™, L6030™, L3020™, L3050™ | 1pc |
| HG17.001 | 0139809 | Filter panel suitable for extraction unit 500 × 600mm, H13 suitable for TUBEMATIC®, TC600L™, TC6000L™ | 1pc |
| HG17.002 | 146122342682 | Filter panel suitable for extraction unit (horizontal) | 1pc |

AIR FILTERS SUITABLE FOR TRUMPF®

| Part No. | Ref. No. | Description | Std. Pkg. | Part No. | Ref. No. | Description | Std. Pkg. |
|----------|----------|---|-----------|----------|----------|---|-----------|
| HG10.178 | HG10.178 | Air filter for cooling aggregate size: 2420 × 550 × 8mm | 25pcs | HG10.190 | HG10.190 | Air filter for cooling aggregate size: 1200 × 700 × 8mm | 25pcs |
| HG10.187 | HG10.187 | Air filter for cooling aggregate size: 1520 × 755 × 8mm | 25pcs | HG10.191 | HG10.191 | Air filter for cooling aggregate size: 990 × 890 × 8mm | 25pcs |
| HG10.188 | HG10.188 | Air filter for cooling aggregate size: 1670 × 660 × 8mm | 25pcs | HG11.175 | HG11.175 | Air filter for cooling aggregate size: 670 × 1200 × 8mm | 25pcs |
| HG11.188 | HG11.188 | Air filter for cooling aggregate size: 1670 × 620 × 8mm | 25pcs | HG11.178 | HG11.178 | Air filter for cooling aggregate size: 2500 × 1710 × 8mm | 5pcs |
| HG10.189 | HG10.189 | Air filter for cooling aggregate size: 2420 × 560 × 8mm | 25pcs | HG11.187 | HG11.187 | Air filter for cooling aggregate size 1530 × 1530 × 8mm | 5pcs |
| HG11.174 | HG11.174 | Air filter for cooling aggregate size: 3000 × 1800 × 8mm | 5pcs | HG10.176 | HG10.176 | Air filter for cooling aggregate size: 800 × 600 × 8mm | 25pcs |

Last update of this page: 09/09/2013. See Revision history for details.

THERMACUT®
THE CUTTING COMPANY®

WWW.THERMACUT.CZ
TEL.: +420 556 423 418
SALES@THERMACUT.CZ

WWW.THERMACUT.DE
TEL.: +49 (0) 27 39 40 33 0
INFO@THERMACUT.DE

WWW.THERMACUT.COM
TEL.: 1-603-542-6715
CUSTOMERSERVICE@THERMACUT.COM

THERMACUT®, THE CUTTING COMPANY®, FHT-EX®, EX-TRAFIRE®, EX-TRACK®, EX-TRABEAM® AND EX-TRAFLEAME® ARE REGISTERED TRADEMARKS OF THERMACUT, K.S. AND MAY BE REGISTERED IN CZECH REPUBLIC AND/OR OTHER COUNTRIES. ALL OTHER TRADEMARKS ARE PROPERTIES OF THEIR RESPECTIVE OWNERS. THERMACUT IS NO WAY AFFILIATED WITH TRUMPF®. MOST THERMACUT PARTS ARE MADE FOR OR BY AN IBG COMPANY.

VALID FROM JANUARY 2021 • PREVIOUS VERSION IS NO LONGER VALID. • © COPYRIGHT 2021 BY THERMACUT® CZECH REPUBLIC. ALL RIGHTS RESERVED.

THERMACUT® REPLACEMENT PARTS SUITABLE FOR RAYTOOLS™

| Part No. | Ref. No. | Description | Std. Pkg. | Part No. | Ref. No. | Description | Std. Pkg. |
|----------|------------|-------------------------|-----------|----------|------------|------------------------------|-----------|
| HG11.051 | 120GJT0508 | Nozzle 0.8mm | 10pcs | HG11.061 | 120GJT0610 | Double Nozzle 1.0mm HCP | 10pcs |
| HG11.052 | 120GJT0510 | Nozzle 1.0mm | 10pcs | HG11.062 | 120GJT0612 | Double Nozzle 1.2mm HCP | 10pcs |
| HG11.053 | 120GJT0512 | Nozzle 1.2mm | 10pcs | HG11.063 | 120GJT0615 | Double Nozzle 1.5mm HCP | 10pcs |
| HG11.054 | 120GJT0515 | Nozzle 1.5mm | 10pcs | HG11.064 | 120GJT0620 | Double Nozzle 2.0mm HCP | 10pcs |
| HG11.055 | 120GJT0520 | Nozzle 2.0mm | 10pcs | HG11.065 | 120GJT0625 | Double Nozzle 2.5mm HCP | 10pcs |
| HG11.056 | 120GJT0525 | Nozzle 2.5mm | 10pcs | HG11.066 | 120GJT0630 | Double Nozzle 3.0mm HCP | 10pcs |
| HG11.057 | 120GJT0530 | Nozzle 3.0mm | 10pcs | HG11.067 | 120GJT0635 | Double Nozzle 3.5mm HCP | 10pcs |
| HG11.058 | 120GJT0535 | Nozzle 3.5mm | 10pcs | HG11.068 | 120GJT0640 | Double Nozzle 4.0mm HCP | 10pcs |
| HG11.059 | 120GJT0540 | Nozzle 4.0mm | 10pcs | HG11.069 | HG11.069 | Protection Window 27.9 × 4.1 | 1pc |
| HG11.060 | 120GJT0608 | Double Nozzle 0.8mm HCP | 10pcs | HG11.050 | 120274100B | Nozzle Holder | 1pc |

THERMACUT® REPLACEMENT PARTS SUITABLE FOR BODOR™

| Part No. | Ref. No. | Description | Std. Pkg. | Part No. | Ref. No. | Description | Std. Pkg. |
|----------|----------|---------------------|-----------|----------|----------|---------------------|-----------|
| HG11.070 | HG11.070 | Nozzle 0.8mm | 10pcs | HG11.082 | HG11.082 | Double Nozzle 1.0mm | 10pcs |
| HG11.071 | HG11.071 | Nozzle 1.0mm | 10pcs | HG11.083 | HG11.083 | Double Nozzle 1.2mm | 10pcs |
| HG11.072 | HG11.072 | Nozzle 1.2mm | 10pcs | HG11.084 | HG11.084 | Double Nozzle 1.5mm | 10pcs |
| HG11.073 | HG11.073 | Nozzle 1.5mm | 10pcs | HG11.085 | HG11.085 | Double Nozzle 2.0mm | 10pcs |
| HG11.074 | HG11.074 | Nozzle 2.0mm | 10pcs | HG11.086 | HG11.086 | Double Nozzle 2.5mm | 10pcs |
| HG11.075 | HG11.075 | Nozzle 2.5mm | 10pcs | HG11.087 | HG11.087 | Double Nozzle 3.0mm | 10pcs |
| HG11.076 | HG11.076 | Nozzle 3.0mm | 10pcs | HG11.088 | HG11.088 | Double Nozzle 3.5mm | 10pcs |
| HG11.077 | HG11.077 | Nozzle 3.5mm | 10pcs | HG11.089 | HG11.089 | Double Nozzle 4.0mm | 10pcs |
| HG11.078 | HG11.078 | Nozzle 4.0mm | 10pcs | HG11.090 | HG11.090 | Double Nozzle 4.5mm | 10pcs |
| HG11.079 | HG11.079 | Nozzle 4.5mm | 10pcs | HG11.091 | HG11.091 | Double Nozzle 5.0mm | 10pcs |
| HG11.080 | HG11.080 | Nozzle 5.0mm | 10pcs | | | | |
| HG11.081 | HG11.081 | Double Nozzle 0.8mm | 10pcs | | | | |

Last update of this page: 27/04/2020. See Revision history for details.

THERMACUT®
THE CUTTING COMPANY®

WWW.THERMACUT.CZ
TEL.: +420 556 423 418
SALES@THERMACUT.CZ

WWW.THERMACUT.DE
TEL.: +49 (0) 27 39 40 33 0
INFO@THERMACUT.DE

WWW.THERMACUT.COM
TEL.: 1-603-542-6715
CUSTOMERSERVICE@THERMACUT.COM

THERMACUT®, THE CUTTING COMPANY®, FHT-EX®, EX-TRAFIRE®, EX-TRACK®, EX-TRABEAM® AND EX-TRAFLEAME® ARE REGISTERED TRADEMARKS OF THERMACUT, K.S. AND MAY BE REGISTERED IN CZECH REPUBLIC AND/OR OTHER COUNTRIES. ALL OTHER TRADEMARKS ARE PROPERTIES OF THEIR RESPECTIVE OWNERS. THERMACUT IS NO WAY AFFILIATED WITH BODOR™ AND RAYTOOLS™. MOST THERMACUT PARTS ARE MADE FOR OR BY AN IBG COMPANY.
VALID FROM JANUARY 2021 • PREVIOUS VERSION IS NO LONGER VALID. • © COPYRIGHT 2021 BY THERMACUT® CZECH REPUBLIC. ALL RIGHTS RESERVED.

REVISION HISTORY

INTRODUCTORY SECTION - Revision on PAGES 6 - 13/01/2021 - Vietnamese contact information changed.

ALL SECTIONS - 21/07/2020 - Revision of all pictures in the catalog.

mitsubishi® SECTION - Revision on PAGE 20 - 21/07/2020 - Ref. No. of parts HG12.506, HG12.507, HG12.508, HG12.509, HG12.521 changed.

MAZAK® SECTION - Revision on PAGE 20 - 21/07/2020 - Ref. No. of part HG10.698 changed to 46143310392. Ref. No. for parts HG10.689/D, HG10.690/D, HG10.691/D added.

AMADA® SECTION - Revision on PAGE 9 - 27/04/2020 - Parts HG11.500, HG11.501, HG11.502, HG11.503, HG11.504, HG11.505, HG11.506 added to the table.

CINCINNATI® SECTION - Revision on PAGE 15 - 27/04/2020 - Parts HG12.041, HG12.042, HG12.040 added to the table. Description of parts HG12.034, HG12.023, HG12.024, HG12.031, HG12.025, HG12.032, HG12.028, HG12.035, HG12.029, HG12.026, HG12.033, HG12.027, HG12.030 changed.

TRUMPF® SECTION - Revision on PAGE 33 - 27/04/2020 - Parts HG10.092, HG10.093, HG10.094, HG10.095 added to the picture and to the table. Part HG10.045 added.

TRUMPF® SECTION - Revision on PAGE 35 - 27/04/2020 - Picture of part HG10.041 removed.

RAYTOOLS™, BODOR™ SECTION - Revision on PAGE 41 - 27/04/2020 - New system added to the catalog.

INTRODUCTORY SECTION - Revision on PAGE 2 - 20/05/2019 - Introductory text updated.

INTRODUCTORY SECTION - Revision on PAGES 3, 6 - 28/02/2019 - Czech and United Arab Emirates contact informations changed.

Precitec® SECTION - Revision on PAGE 28 - 28/02/2019 - Description of parts HG10.621/H, HG15.002/H corrected.

TRUMPF® SECTION - Revision on PAGE 35 - 28/02/2019 - Part HG10.041 added to the picture and to the table.

INTRODUCTORY SECTION - Revision on PAGES 3-6 - 18/09/2018 - Japanese contact informations changed.

SALVAGNINI® SECTION - 02/07/2018 - Section removed from the catalog.

AMADA® SECTION - Revision on PAGE 8 - 02/07/2018 - Product line AMADA® LASER HS™ 95 removed. Parts HG10.608-HG10.614 removed from the picture. Parts HG10.763, HG10.765, HG10.766, HG10.773, HG10.776 added to the picture.

CINCINNATI® SECTION - Revision on PAGE 15 - 02/07/2018 - Lenses section added to the catalog.

LVD® SECTION - Revision on PAGE 16 - 02/07/2018 - Heading "Standard copper nozzles / Standard copper nozzles with hard chromium plating" removed.